

TECHNICAL MANUAL

OPERATOR'S MANUAL

**GENERATOR SET,
SKID MOUNTED, TACTICAL QUIET**

60 KW, 50/60 AND 400 HZ

MEP-806A (50/60 HZ) 6115-01-274-7390

MEP-816A (400 HZ) 6115-01-274-7395

**EQUIPMENT
DESCRIPTION
PAGE 1-4**

**OPERATING
INSTRUCTIONS
PAGE 2-1**

**PREVENTIVE
MAINTENANCE
PAGE 2-8**

**LUBRICATION
INSTRUCTIONS
PAGE 3-1**

**TROUBLESHOOTING
PROCEDURES
PAGE 3-1**

**MAINTENANCE
PROCEDURES
PAGE 3-11**

**INDEX
PAGE I-1**

*This manual supersedes TM 9-6115-645-10 dated 30 December 1992.

DISTRIBUTION STATEMENT A: Approved for public release; distribution is unlimited

**HEADQUARTERS, DEPARTMENTS OF THE ARMY,
AIR FORCE AND HEADQUARTERS U.S. MARINE CORPS
30 JULY 1993**

CHANGE

HEADQUARTERS, DEPARTMENTS OF
THE ARMY AND AIR FORCE, AND
HEADQUARTERS, U.S. MARINE CORPS
WASHINGTON, D.C., 30 October 1996

NO. 2

**Operator's Manual
GENERATOR SET,
SKID MOUNTED, TACTICAL QUIET**

**60 KW, 50/60 AND 400 HZ
MEP-806A (50/60 HZ) 6115-01-274-7390
MEP-816A (400 HZ) 6115-01-274-7395**

DISTRIBUTION STATEMENT A: Approved for public release; distribution is unlimited

TM 9-6115-645-10/TO 35C2-3-444-1 1/TM 09244A/09245A-10/1, 30 July 1993, is changed as follows:

1. Remove and insert pages as indicated below. New or changed text material is indicated by a vertical bar in the margin. An illustration change is indicated by a miniature pointing hand.

Remove pages
i through iv
1-7 and 1-8
2-5 through 2-10
2-17 and 2-18

2-33 through 2-36
2-39 and 2-40
3-9 and 3-10

Insert pages
i through iv
1-7 and 1-8
2-5 through 2-10
2-17 and 2-18
2-32.1/(2-32.2 blank)
2-33 through 2-36
2-39 and 2-40
3-9 and 3-10

2. Retain this sheet in front of manual for reference purposes.

ARMY TM 9-6115 645 10
AIR FORCE TO 35C2- 3-444 11
MARINE CORPS TM 09244A/09245A-10/1
C2

By Order of the Secretaries of the Army, Air Force, and Navy (Including the Marine Corps):

Official: 
JOEL B. HUDSON
*Administrative Assistant to the
Secretary of the Army*
02878

DENNIS J. REIMER
General, United States Army
Chief of Staff

RONALD R. FOGELMAN
General, USAF
Chief of Staff

Official:

HENRY VICCELLO, JR.
General, USAF
Commander, Air Force Materiel Command

J. E. BUFFINGTON
Rear Admiral, CEC, US Navy
Commander
Navy Facilities Engineering
Command

D. R. BLOOMER
Colonel, USMC
Director, Program Support
Marine Corps Systems Command

DISTRIBUTION:

To be distributed in accordance with DA Form 12-25-E, block no.5269, requirements for TM 9-6115-645-10.

CHANGE

HEADQUARTERS DEPARTMENTS OF
THE ARMY AND THE AIR FORCE, AND
HEADQUARTERS, U.S. MARINE CORPS
WASHINGTON, D. C., 31 May 1995

NO. 1

**Operator's Manual
GENERATOR SET,
SKID MOUNTED, TACTICAL QUIET**

**60 KW, 50/60 AND 400 HZ
MEP-806A (50/60 HZ) 6115-01-274-7390
MEP-816A (400 HZ) 6115-01-274-7395**

DISTRIBUTION STATEMENT A: Approved for public release; distribution is unlimited

TM 9-6115-645-10/TO 35C2-3-444-11/TM 09244A/09245A-10/1, 30 July 1993, is changed as follows:

1. Remove and insert pages as indicated below. New or changed text material is indicated by a vertical bar in the margin. An illustration change is indicated by a miniature pointing hand.

Remove pages

i and ii
1-11 through 1-14
2-9 and 2-10
2-21 and 2-22
2-29 and 2-30
2-39 and 2-40
3-3 and 3-4
3-7 and 3-8

Insert pages

i and ii
1-11 through 1-14
2-9 and 2-10
2-21 and 2-22
2-29 and 2-30
2-39 and 2-40
3-3 and 3-4
3-7 and 3-8

2. Retain this sheet in front of manual for reference purposes.

By Order of the Secretaries of the Army, Air Force, and Navy (Including the Marine Corps):

Official:



JOEL B. HUDSON

*Acting Administrative Assistant to the
Secretary of the Army*

00164

GORDON R. SULLIVAN
*General, United States Army
Chief of Staff*

RONALD R. FOGELMAN
*General, USAF
Chief of Staff*

RONALD W. YATES
*General, USAF
Commander Air Force Materiel Command*

JACK E. BUFFINGTON
*Rear Admiral, CEC, US Navy
Commander
Navy Facilities Engineering
Command*

D. R. BLOOMER
*Colonel, USMC
Director Program Support
Marine Corps Systems Command*

DISTRIBUTION:

To be distributed in accordance with DA Form 12-25-E, block no. 5269, requirements for TM 9-6115-645-10.

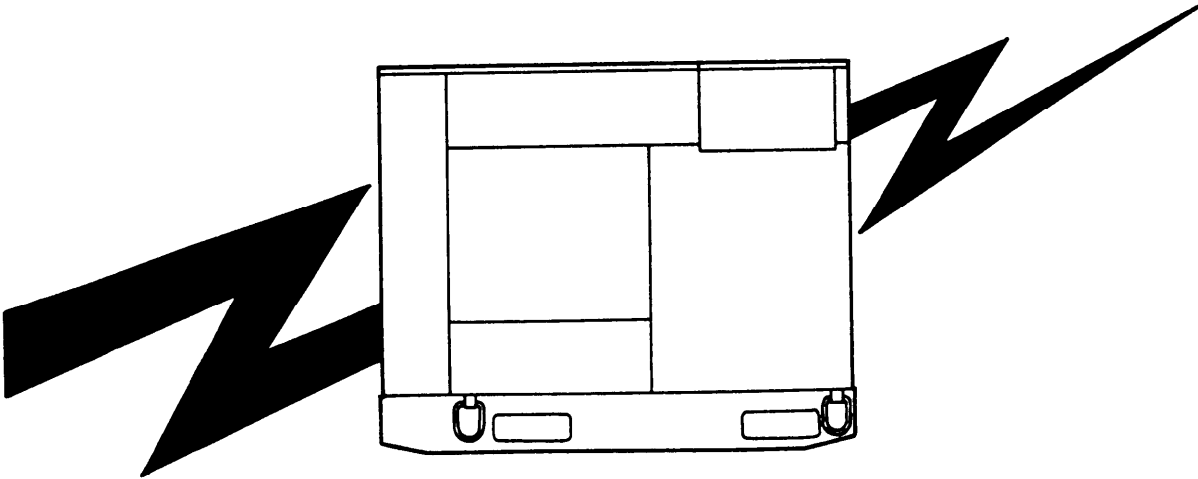

WARNING

High voltage is produced when this generator set is in operation. Improper operation could result in personal injury or death.

WARNING

Never attempt to start the generator set if it is not properly grounded. Failure to observe this warning could result in serious injury or death by electrocution.

WARNING

Never attempt to connect or disconnect load cables while the generator is running. Failure to observe this warning could result in serious personal injury or death by electrocution.

WARNING

DC voltages are present at generator set electrical components even with generator set shut down. Avoid grounding could result in severe any electrical components. Failure to observe this warning can result in personal injury.

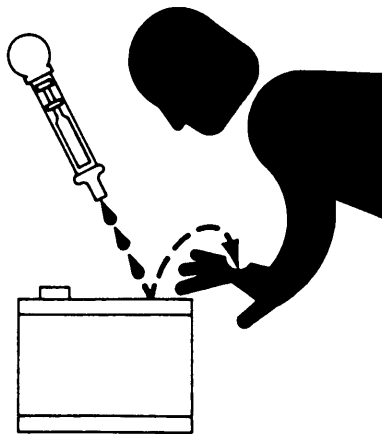

WARNING

Battery acid can cause burns to unprotected skin.

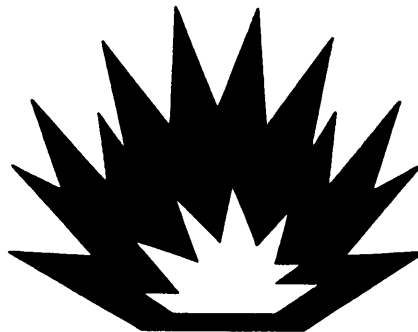

WARNING

The fuels in this generator set are highly explosive. DO NOT smoke or use open flame when performing maintenance. Flames and explosion can occur resulting in severe personal injury or death.

WARNING

DO NOT refuel the generator set while it is operating. Hot refueling of the generator set while in operation presents a safety hazard and should not be attempted. Hot engine surfaces and sparks produced from the engine and generator circuitry are possible sources of ignition. Flames and explosion can occur resulting in severe personal injury or death.

WARNING

Batteries give off flammable gas. Do not smoke or use open flame when performing maintenance. Flames and explosion could result in personal injury or death.



WARNING

Exhaust discharge contains deadly gases. Do not operate generator set in enclosed area unless exhaust discharge is properly vented outside. Severe personal injury or death due to carbon monoxide poisoning could result.

WARNING

Do not manually discharge or deliberately inhale ether. Breathing ether fumes can cause fainting.



WARNING

Liquids under pressure are generated as a result of operation of the generator set. High pressure leaks could cause severe personal injury or death.



WARNING

With any access door open, the noise level of this generator set when operating could cause hearing damage. Hearing protection must be worn when working near the generator set while running.

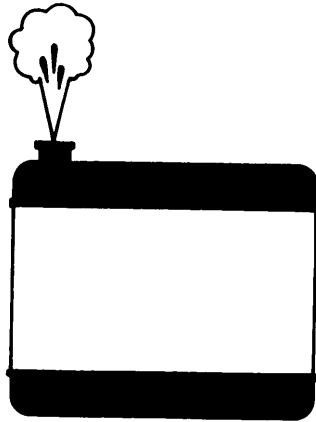

WARNING

Cooling system operates at high temperatures. Personal injury or death from burns or scalding can result from contact with high pressure steam and/or liquid.



WARNING

Avoid contacting metal items with bare skin in extreme cold weather. Failure to observe this warning can result in personal injury.

FOR FIRST AID REFER TO FM 21-11

TECHNICAL MANUAL

NO.9-6115-645-10

HEADQUARTERS, DEPARTMENTS OF
THE ARMY AND AIR FORCE, AND
HEADQUARTERS, U.S. MARINE CORPS
WASHINGTON, D.C., 30 July 1993

Operator's Manual

**GENERATOR SET, SEID MOUNTED, TACTICAL QUIET
60 KW, 50/60 AND 400 HZ
MEP-806A (50/60 HZ) 6115-01-274-7390
MEP-816A (400 HZ) 6115-01-274-7395**

Distribution Statement A: Approved for public release; distribution is unlimited.

REPORTING OF ERRORS AND RECOMMENDING IMPROVEMENTS

You can help improve this manual. If you find any mistakes or if you know of a way to improve the procedures, please let us know.

(A): Army Mail your letter or DA Form 2028 (Recommended Changes to Publications and Blank Forms), or DA Form 2028-2 located in the back of this manual directly to: Commander, US Army Aviation and Troop Command, ATTN: AMSAT-I-MP, 4300 Goodfellow Blvd., St. Louis, MO 63120-1798. You may also submit your recommended changes by E-mail directly to <mpmt%/oavma28@st-louis-emh7.army.mii>. Instructions for sending an electronic 2028 may be found at the back of this publication immediately preceding the hard copy 2028.

(F): Air Force AFTO Form 22 directly to: Commander, Sacramento Air Logistics Center, ATTN: TILBA, McClellan AFB, CA 95652-5990.

(M): Marine Corps NVMC Form 10772 directly to: Commander, Marine Corps Logistics Bases (Code 850), Albany. GA 31004-5000.

A reply will be furnished directly to you.

* This manual supersedes TM 9-6115-645-10 dated 30 December 1992.

TABLE OF CONTENTS

		Page
	HOW TO USE THIS MANUAL	v
CHAPTER 1	INTRODUCTION	1-1
Section I	General Information	1-1
Section II	Equipment Description	1-4
Section III	Technical Principles of Operations	1-12
CHAPTER 2	OPERATING INSTRUCTIONS	2-1
Section I	Description and Use of Operator's Controls and Indicators	2-1
Section II	Preventive Maintenance Checks and Services (PMCS)	2-8
Section III	Operation Under Usual Conditions	2-17
Section IV	Operation Under Unusual Conditions	2-37
CHAPTER 3	MAINTENANCE INSTRUCTIONS	3-1
Section I	Lubrication Instructions	3-1
Section II	Troubleshooting	3-1
	Symptom Index	3-2
Section III	Maintenance Procedures	3-11
APPENDIX A.	REFERENCES	A-1
APPENDIX B.	COMPONENTS OF END ITEM (COEI) AND BASIC ISSUE ITEMS (BII) LISTS	B-1
APPENDIX C.	ADDITIONAL AUTHORIZATION LIST (AAL)	C-1
APPENDIX D.	EXPENDABLE/DURABLE SUPPLIES AND MATERIALS LIST (EDSML)	D-1
	INDEX	I-1

LIST OF ILLUSTRATIONS

Number	Title	Page
1-1	Generator Set, 60kW, Tactical Quiet	1-2
1-2	Generator Set Components	1-5
1-3	Engine Starting System.....	1-12
1-4	Fuel System	1-13
1-5	Engine Cooling System.....	1-14
1-6	Engine Lubrication System.....	1-15
1-7	Air Intake and Exhaust System	1-16
1-8	Output Supply System.....	1-17
2-1	Control Panel / Controls Bracket Assembly.	2-2
2-2	Malfunction Indicator Panel	2-6
2-3	Grounding Connections.....	2-18
2-4	Installation of Load Cables	2-21
2-5	Parallel Operation Setup	2-25
2-6	Operating Instructions Plates (Front and Right Side).....	2-30
2-7	Operating Instructions Plates (Rear and Left Side)	2-31
2-8	Operating Instructions Plate	2-32
2-9	Identification Plates	2-32.1
2-10	Set Rating Identification Plate	2-33
2-10.1	Fuel System Diagram Plate.....	2-33
2-11	Voltage Connection Caution Plate.....	2-34
2-12	Grounding Stud Plate	2-34
2-13	NATO Slave Receptacle Plate	2-34
2-14	Paralleling Receptacle Plate.....	2-34
2-15	Convenience Receptacle Plate	2-34
2-16	External Fuel Supply Plate	2-34
2-17	Battery Connection Instruction Plate	2-35
2-18	Lifting and Tiedown Diagram Plate	2-35
2-19	Diagnostics Plate.....	2-36
2-20	Generator Identification Plate.....	2-36
3-1	Air Cleaner Element Replacement.....	3-12
3-2	Draining Filter / Water Separator	3-16

LIST OF TABLES

Number	Title	Page
1-1	Leading Particulars	1-7
2-1	Control Panel Controls and Indicators	2-3
2-2	Malfunction Indicator Panel	2-7
2-3	Operator Preventive Maintenance" Checks and Services (PMCS)	2-10
2-4	Load Terminal, AC Reconnection Board and AM-VM Transfer Switch Selection	2-20
3-1	Troubleshooting	3-4
3-2	Coolant	3-14
3-3	Diesel Fuel	3-15

HOW TO USE THIS MANUAL

In this manual (TM 9-6115-645-10), paragraphs are underlined and the sections and chapters appear in capital letters. The location of additional material that must be referenced is clearly marked. Drawings in this text are located as close as possible to their references.

Chapter 1 - Introduction. Chapter 1 contains general information, equipment description and technical principles of operation.

Chapter 2 - Operating Instructions. Chapter 2 contains a description of generator set operation controls and indicators. The control panel assembly is illustrated and each control and indicator is described in a follow-on table. Operating procedures which include Preventive Maintenance Checks and Services (PMCS) and operation under usual and unusual conditions are detailed.

Chapter 3 - Maintenance. Chapter 3 lists maintenance procedures authorized at the operator level, and troubleshooting procedures used to recognize generator set malfunction, test or inspection, and corrective action.

Appendices.

Appendix A is a list of the other publications referenced by this manual. Included are other manuals which should be used with this operator's manual.

Appendix B is the Components of End Item (COEI) and Basic Issue Items (BII) Lists.

Appendix C is the Additional Authorization List (AAL).

Appendix D is the Expendable/Durable Supplies and Materials List (EDSML).

Index. The index contains key technical manual subjects arranged in alphabetical order. If you require information on a specific subject (i.e., starting), but you are not sure where to look, use index to locate specific page.

CHAPTER 1

INTRODUCTION

SECTION I. GENERAL INFORMATION

1-1 SCOPE.

1-1.1 Type of Manual. This manual contains operation and operator maintenance instructions for the Tactical Quiet (TQ), 60 kW 50/60 and 400 Hz Generator Sets (FIGURE 1-1), herein referred to as generator set. Included are descriptions of major components and their functions in relation to other components.

1-1.2 Model Numbers and Equipment Names.

<u>Model Number</u>	<u>Equipment Name</u>
MEP-806A	Generator Set, Skid Mounted, Tactical Quiet 60 kW 50/60 Hz.
MEP-816A	Generator Set, Skid Mounted, Tactical Quiet 60 kW 400 Hz.

1-1.3 Purpose of Equipment.

The generator set provides tactical quiet AC power. The generator set is easily transported, operated, and maintained.

1-2 MAINTENANCE FORMS AND RECORDS.

1-2.1 (A) Department of the Army forms and procedures used for equipment maintenance will

be those prescribed by DA PAM 738-750, The Army Maintenance Management System (TAMMS).

1-2.2 (F) Maintenance Forms and Records maintained by the Air Force are prescribed in AFR 66-1 and the applicable TO 00-20 Series Technical Orders.

1-2.3 (N) Navy users should refer to their service peculiar directives to determine the applicable maintenance forms and records to be used.

1-2.4 (MC) Maintenance Forms and Records used by the Marine Corps personnel are prescribed by the current edition of TM 4700-15/1.

1-3 REPORTING EQUIPMENT IMPROVEMENT RECOMMENDATIONS (EIR).

1-3.1 If your generator set needs improvement, let us know. Send us an EIR. You, the user, are the only one who can tell us what you don't like about your equipment. Let us know why you don't like the design or performance. We will send you a reply.

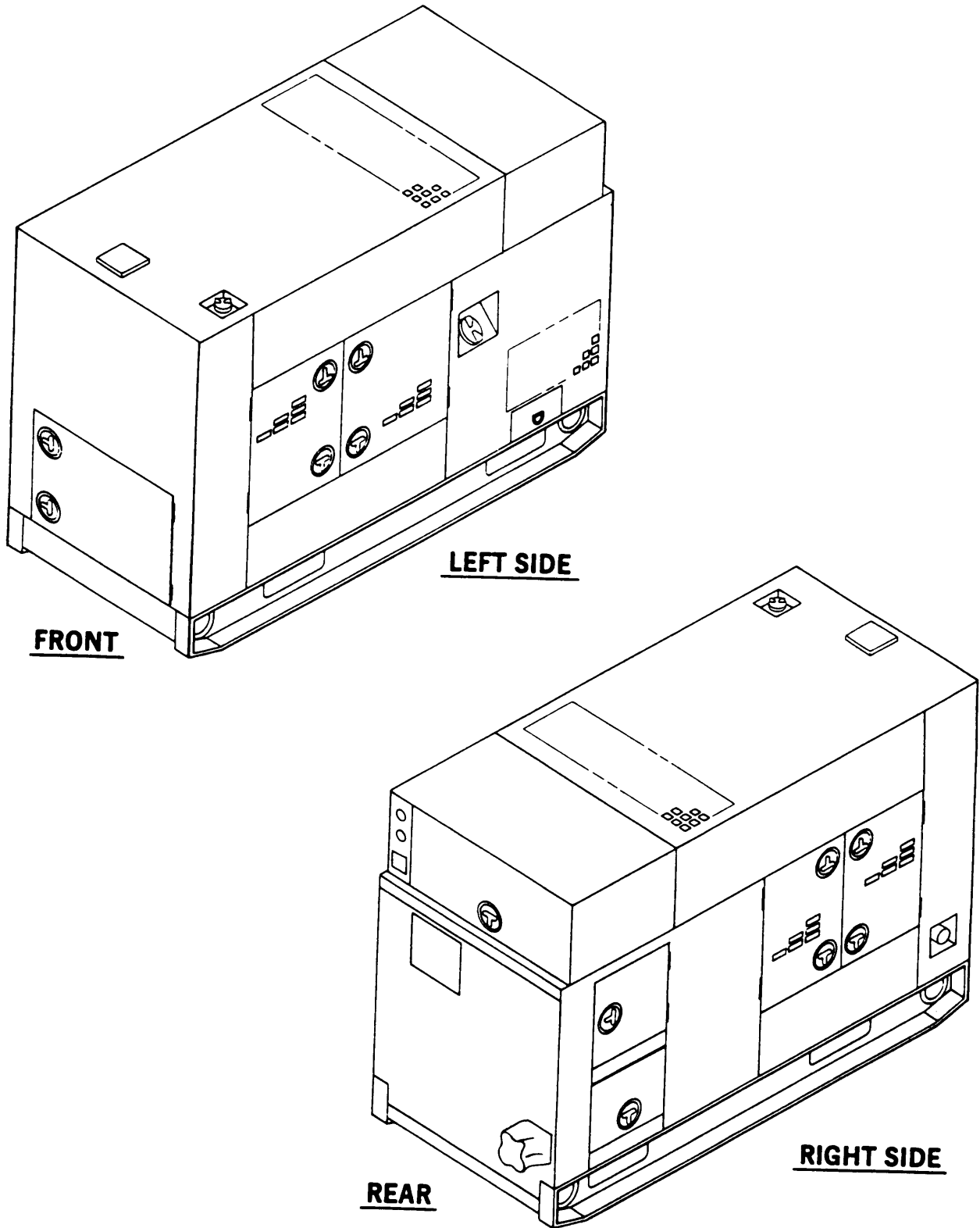

FIGURE 1-1. Generator Set, 60 kW, Tactical Quiet

1-3.2 (A) Put it on an SF 368 (Quality Deficiency Report). EIRs should be mailed directly to:

Commander
U.S. Army Troop Support Command
Attn: AMSTR-MOF
4300 Goodfellow Blvd.
St. Louis, MO 63120-1798

1-3.3 (N) Put it on applicable Navy form and mail it directly to:

Naval Construction Battalion
Center
Attn: Code 157 Civil Engineer
Support Office (CESO)
Port Hueneme,
CA 93043-5000

1-3.4 (MC) Quality Deficiency Reports (QDR) shall be submitted on SF 368 in accordance with MCO 4855.10. Submit to:

Commander
Marine Corps Logistics Bases
(Code 856)
Albany, GA 31704-5000

1-3.5 (F) Quality Deficiency Reports/Materiel Deficiency Reports shall be sent by electronic message to: SMALC CA//TILE//.

1-4 WARRANTY INFORMATION.

The generator sets (MEP-806A and MEP-816A) are warranted by Libby Corporation for a period of 36 months or 1800 operating hours, whichever

occurs first. Refer to Warranty Technical Bulletin TB 9-6115-645-24. The warranty starts on the date found in block 23, DA Form 2408-9, in the logbook. Report all defects in material or workmanship to your supervisor, who will take appropriate action through your Unit Maintenance Shop.

1-5 LIST OF ABBREVIATIONS.

The following list of abbreviations consists of those special or unique abbreviations that are not contained in MIL-STD-12 and do not conflict with those in MIL-STD-12.

<u>Abbreviation</u>	<u>Description</u>
KPA	Kilopascal
KVA	Kilovolt-ampere
kW	Kilowatt
CTA	Common Table of Allowance
MTOE	Modified Table of Organization and Equipment
NATO	North Atlantic Treaty Organization
JTA	Joint Table of Allowances
AOAP	Army Oil Analysis Program

SECTION II. EQUIPMENT DESCRIPTION

1-6 EQUIPMENT CHARACTERISTICS, CAPABILITIES AND FEATURES.

The generator sets, models MEP-806A and MEP-816A (FIGURE 1-2), are fully enclosed, self-contained, skid-mounted, portable units. They are equipped with controls, instruments and accessories necessary for operation as single units or in parallel with another unit of the same class and mode. The generator sets consist of a diesel engine, brushless generator, excitation system, speed governing system, fuel system, 24 VDC starting system, control system and fault system.

NOTE

All locations referenced in FIGURE 1-2 are given facing the control panel assembly (rear) of the generator set.

1-7 LOCATION AND DESCRIPTION OF MAJOR COMPONENTS.

1-7.1 Engine (19). The generator is powered by a six cylinder, four cycle, fuel injected, turbocharged, liquid-cooled diesel engine which occupies the front half of the generator set. The engine is also equipped with a fuel filter/water separator, oil filter, and an air cleaner assembly. Protection devices automatically stop the engine during conditions of high coolant temperature, low oil pressure, no fuel, over-speed, or over-voltage.

1-7.2 Radiator (22). The radiator is located at the front of the generator set. It acts as a heat exchanger for the engine coolant.

1-7.3 Muffler (3). The muffler and exhaust tubing are connected to the exhaust manifold on the engine. The exhaust exits from the top of the generator set housing. Gases are exhausted upward.

1-7.4 Starter (9). The starter is located on the right side of the engine. The electric starter mechanically engages the engine flywheel in order to start the diesel engine.

1-7.5 Battery Charging Alternator (6). The battery charging alternator is located on the right side of the engine. It is capable of maintaining the batteries in a state of full charge in addition to providing the required 24 VDC control power.

1-7.6 Batteries (23). Two batteries are located at front of the generator set. The batteries are electrolyte serviceable, lead acid, 12 volt type, connected in series. After starting, the generator set is capable of operating with batteries removed. A diode and a fuse, located behind the control panel assembly, protect the generator set if the batteries are incorrectly connected.

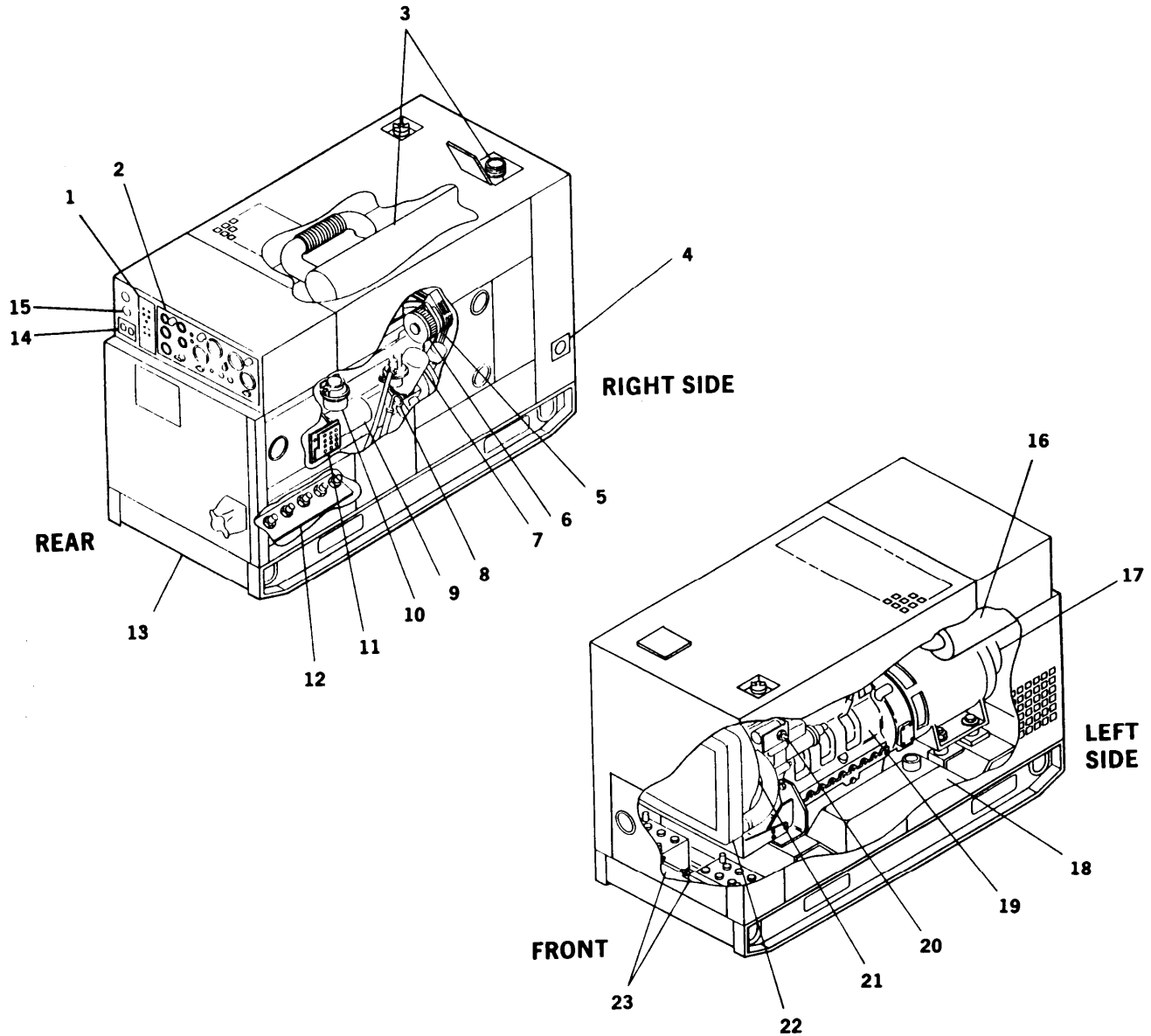

- | | | | |
|----|-------------------------------------|----|----------------------------|
| 1 | Malfunction Indicator Panel | 12 | Load Output Terminal Board |
| 2 | Control Panel Assembly | 13 | Skid Base |
| 3 | Muffler | 14 | Convenience Receptacle |
| 4 | NATO Slave Receptacle | 15 | Paralleling Receptacle |
| 5 | Fan Belts | 16 | Air Cleaner Assembly |
| 6 | Battery Charging Alternator | 17 | AC Generator |
| 7 | Oil Filter | 18 | Fuel Tank |
| 8 | Dipstick | 19 | Engine |
| 9 | Starter | 20 | Dead Crank Switch |
| 10 | Fuel Filter/Water Separator | 21 | Water Pump |
| 11 | Voltage Reconnection Terminal Board | 22 | Radiator |
| | | 23 | Batteries |

FIGURE 1-2. Generator Set Components

1-7.7 Air Cleaner Assembly (16). The air cleaner assembly is located on the left side behind the air cleaner access door. It consists of a dry-type, disposable paper element and canister. The air cleaner assembly features a dust collector which traps large dust particles. The air cleaner assembly has a restriction indicator which will indicate when the air cleaner element requires servicing.

1-7.8 Fuel Tank (18). The fuel tank is located below the engine and between the skid base side members. The fuel tank has a capacity of 43 gallons (162.7 liters) which will allow the generator set to operate for at least 8 hours without refueling.

1-7.9 AC Generator (17). The AC generator is a single bearing, drip-proof, synchronous, brushless, three phase, fan-cooled generator. The generator is coupled directly to the rear of the diesel engine.

1-7.10 Load Output Terminal Board (12). The load output terminal board is located on the right side (rear) of the generator set. There are four output terminals located on the board. They are marked L1, L2, L3 and L0. A fifth terminal, marked GND, is located next to the output terminals and serves as equipment ground for the generator set. A removable, solid copper bar is connected between the L0 and GND terminals.

1-7.11 Control Panel Assembly (2). The generator set control panel assembly is located at the rear of the generator set and

contains controls and instruments for operating the engine and the generator.

1-7.12 Malfunction Indicator Panel (1). The malfunction indicator panel is located to the left of the control panel assembly. It indicates malfunctions of the generator set components.

1-7.13 NATO Slave Receptacle (4). The NATO slave receptacle is located on the right side (front) of the generator set. It is used for slave starting.

1-7.14 Skid Base (13). The skid base supports the generator set. It has fork lift access openings and cross members for short distance movement. The skid base has provisions in the bottom for installation of the generator set on a trailer.

1-7.15 Voltage Reconnection Terminal Board (11). The voltage reconnection terminal board is located on the right side (rear) of the generator set. The board allows reconfiguration from 120/208 to 240/416 VAC output.

1-7.16 Fuel Filter/Water Separator (10). The fuel filter/water separator is located in the engine compartment on the right side. The element removes impurities and water from the diesel fuel.

1-7.17 Dipstick (8). The dipstick is located in the engine compartment on the right side. The dipstick shows the lubricating oil level in the engine crankcase.

1-7.18 Oil Filter (7). The oil filter is located in the engine compartment on the left side. The filter removes impurities from the engine lubricating oil.

1-7.19 Fan Belts (5). The fan belt is located in the engine compartment on the front of the engine. The belt drives the fan, water pump and battery charging alternator.

1-7.20 Water Pump(21). The water pump is located in the engine compartment on the front of the engine. The pump circulates the engine coolant through the engine block and the radiator.

1-7.21 Dead Crank Switch (20). The Dead Crank switch is located in the engine compartment on the left side. The switch allows the engine to be cranked without starting for maintenance.

1-7.22 Paralleling Receptacle. The paralleling receptacle is used to connect the paralleling cable between two generator sets of the same size and mode to operate in parallel.

1-7.23 Convenience Receptacle (22). The convenience receptacle is a 10 Amp, 120 VAC receptacle used to operate small plug in type equipment. It is protected by a Ground Fault Circuit Interrupter located below the malfunction indicator (1-7.12), an over load circuit breaker located inside the control box, and an in-line fuse on generator sets, contract number DAAK01-88D-D082. The convenience receptacle power is available at all times during operation of the generator set.

1-8 DIFFERENCES BETWEEN MODELS. The differences between models of the generator sets covered in this manual are as follows:

Model MEP-806A is equipped with a 50/60 Hz generator.

Model MEP-816A is equipped with a 400 Hz generator.

1-9 EQUIPMENT DATA. For a list of Leading Particulars refer to TABLE 1-1.

Table 1-1. Leading Particulars

1. Generator Set:	
Model Numbers	
60 kW 50/60 Hz Tactical Quiet	MEP-806A
60 kW 400 Hz Tactical Quiet	MEP-816A
National Stock Numbers	
60 kW 50/60 Hz Tactical Quiet	NSN 6115-01-274-7390
60 kW 400 Hz Tactical Quiet	NSN 6115-01-274-7395
Overall Length	
MEP-806A	87 in. (221 cm)
MEP-816A	87 in. (221 cm)

Table 1-1. Leading Particulars - Continued

1. Generator Set - Continued:	
Overall Width	
MEP-806A	35.7 in. (90.8 cm)
MEP-816A	35.7 in. (90.8 cm)
Overall Height	
MEP-806A	59 in. (149.9 cm)
MEP-816A	59 in. (149.9 cm)
Dry Weights (less Basic Issue Items)	
MEP-806A	3556 lb. (1613 kg.)
MEP-816A	3606 lb. (1635.7 kg.)
Wet Weights	
MEP-806A	3992 lb. (1810.8 kg.)
MEP-816A	4042 lb. (1833.5 kg.)
2. Engine:	
Manufacturer	John Deere
Model	6059T
Type	six cylinder, four cycle, turbocharged diesel
Displacement	359 cu. in. (5.9 liters)
Altitude Degradation, 4000 ft (1220 m) to 8000 ft (2440m)	3.5% per 1000 ft (305 m)
Firing Order	1, 5, 3, 6, 2, 4
Cold Weather Starting Aid System Use	When temperature is 40°F (4°C) or below
Valve Tappet Clearance Adjustment	
Hot or Cold (Intake)	0.014 in. (0.35 cm)
Hot or Cold (Exhaust)	0.018 in. (0.45 cm)
3. Cooling System:	
Type	Pressurized radiator and pump
Capacity	20.5 qts. (19.4 liters)
Normal Operating Temperature	170-200°F (77-93°C)
Temperature Indicating System	
Voltage Rating	24 VDC
4. Lubricating System:	
Type	Full flow, circulating pressure
Oil Pump Type	Positive displacement gear

TABLE 1-1. Leading Particular - Continued

4. Lubricating System - Continued:		
Normal Operating Pressure	25-60 psi (172-414 kPa)	
Oil Filter Type	Full flow, spin-on, replaceable element	
Lubricating System Capacity	18 qts. (17 liters)	
Pressure Indicating System	24 VDC	
Voltage Rating		
5. Fuel System:		
Type of Fuel	DF-1, DF-2, DF-A, JP4, JP5, JP8	
Fuel Tank Capacity	43 gal. (162.7 liters)	
Fuel Consumption Rate:	50/60 Hz	
	5.06 gal. (19.2 liters) per hour	
	400 Hz	
	5.37 gal. (20.3 liters) per hour	
Auxiliary Fuel Pump:		
Voltage Rating	24 VDC	
Delivery Pressure	5.0-6.5 psi (34.5-65.5 kPa) (max)	
Fuel Level Switch:		
Type	Float	
Current	3.0 amp at 6 to 32 VDC	
6. Engine Starting System:		
Batteries	Two 12 volt, connected in series	
Starter:		
Manufacturer	Nipponde.03nso Co. Ltd	
Model	RE39930A	
Voltage Rating	24 VDC	
Drive Type	Gear Reduction	
Battery Charging Alternator:		
Manufacturer	Prestolite	
Model	8EM3002GC	
Rating	42 amps at 24 VDC	
Protective Fuse	30 amps	
7. AC Generator:		
	MEP-806A	MEP-816A
Manufacturer	Marathon Electric	Marathon Electric

TABLE 1-1. Leading Particulars - Continued

7. AC Generator - Continued:

	MEP-806A	MEP-816A
Type	Rotating field synchronous	Rotating field synchronous
Load Capacity	60 kW	60 kW
Current Ratings:		
120/208 volt connection	60 Hz: 208 amps	400 Hz: 208 amps
240/416 volt connection	104 amps	104 amps
120/208 volt connection	50 Hz: 172 amps	
240/416 volt connection	82 amps	
Power Factor	0.8	0.8
Cooling	fan cooled	fan cooled
Drive Type	direct coupling	direct coupling
Duty Classification	continuous	continuous

8. Governing System:

Load Measuring Unit:	
Manufacturer	
Model	Technology Research
Governor Control Unit:	19310
Manufacturer	
Model	Barber-Colman DYNA 10502-003-0-2

9. Protection Devices:

Low Oil Pressure Switch:	
Trip Pressure	15 ± 3 psi (103.4 ± 20.7 kPa)
Voltage Rating	
Current Rating	24 VDC
Coolant High Temperature Switch:	5 amps
Trip Temperature	
Voltage Rating	225 ± 50 F (107 ± 3° C)
Current Rating	12-120 VDC 2 amps

Table 1-1. Leading Particulars - Continued

9.	Protection Devices:	
	Speed Switch:	
	Element Trip and Reset	
	Voltage Rating	
	Current Rating	
	Overvoltage:	
	Trip Point Conditions	153 ± 3 VAC for no less than 200 milliseconds (120 VAC coil winding)
	Trip Point	No more than 1.25 seconds after trip conditions exist

SECTION III. TECHNICAL PRINCIPLES OF OPERATION

1-10 INTRODUCTION. This section contains functional descriptions of the generator set and explains how the controls and indicators interact with the system.

1-11 ENGINE STARTING SYSTEM.

The Engine Starting System (Figure 1-3), consists of two 12-volt batteries connected in series, a starter, a 24 volt battery charging alternator, a magnetic pickup (for sensing engine speed) and the related switches and relays required for control of the starting system. For engine cranking, battery power is supplied to tie starter motor through the starter solenoid which in turn is controlled by the cranking relay. The starter then engages the engine flywheel causing the engine to turnover. For engine starting, the DEAD CRANK switch must be in the NORMAL position, the DC Control power circuit breaker must be pushed in, the EMERGENCY STOP switch must be in the OUT position, and the MASTER SWITCH is moved to the START position. The cranking relay is then controlled by a circuit consisting of the start relay and crank disconnect switch. As the engine accelerates to the preset speed (sensed by the magnetic pickup), the crank disconnect switch opens and deenergizes the cranking relay to stop and disengage the starter. The starting sequence may also be stopped by moving the MASTER SWITCH to OFF. The engine may be cranked without starting by use of the DEAD CRANK switch. With the DEAD CRANK switch in the CRANK position, the cranking relay, starter solenoid and starter motor are energized without activating any other starting or control function.

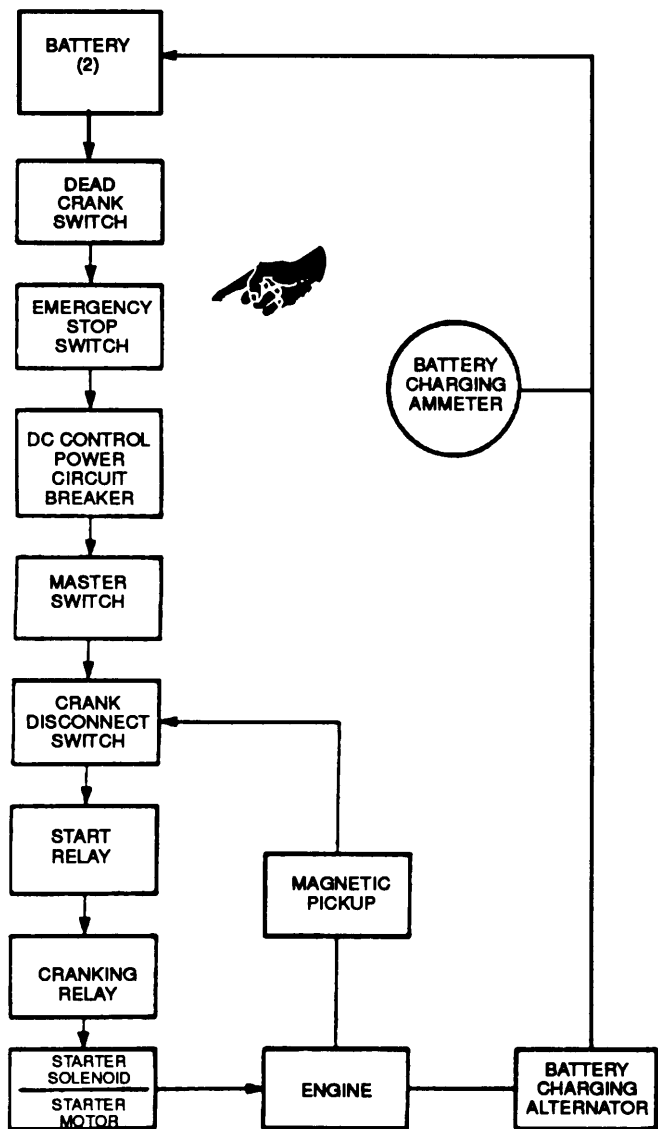

Figure 1-3. Engine Starting System

The batteries are charged by the battery charging alternator that is belt driven by the engine. Generator set control system power is also supplied by the battery charging alternator. The BATTERY CHARGE ammeter indicates the charge/discharge rate of the batteries, from -10 AMPS to +20 AMPS, in 5 AMPS increments. Normal operating indication depends on the state of charge in the batteries. A low charge, such as exists immediately after engine starting, will cause a high reading (needle moves toward CHARGE area). When the charge in the batteries has been restored, the indicator moves near zero.

1-12 FUEL SYSTEM.

1-12.1 The Fuel System (Figure 1-4), consists of piping, fuel tank transfer pump, fuel falter/water separator, injection pump and injectors. Fuel is drawn from the fuel tank by the transfer pump. After reaching the transfer pump, fuel passes through a fuel filter/water separator where water and small impurities are removed. The fuel then goes to an injection pump where it is pressurized and pushed into the injectors. Through the injectors fuel enters the diesel engine combustion chamber, where it is mixed with air and ignited. The fuel that is not used is returned to the fuel tank via an excess fuel return line.

1-12.2 The Auxiliary Fuel System consists of an external fuel supply, fuel filter, piping, a 24 VDC auxiliary fuel pump and a fuel level float switch. When the MASTER SWITCH is set on PRIME & RUN AUX FUEL it actuates the auxiliary fuel pump and transfers fuel from the external fuel supply to the generator fuel tank. The fuel level float

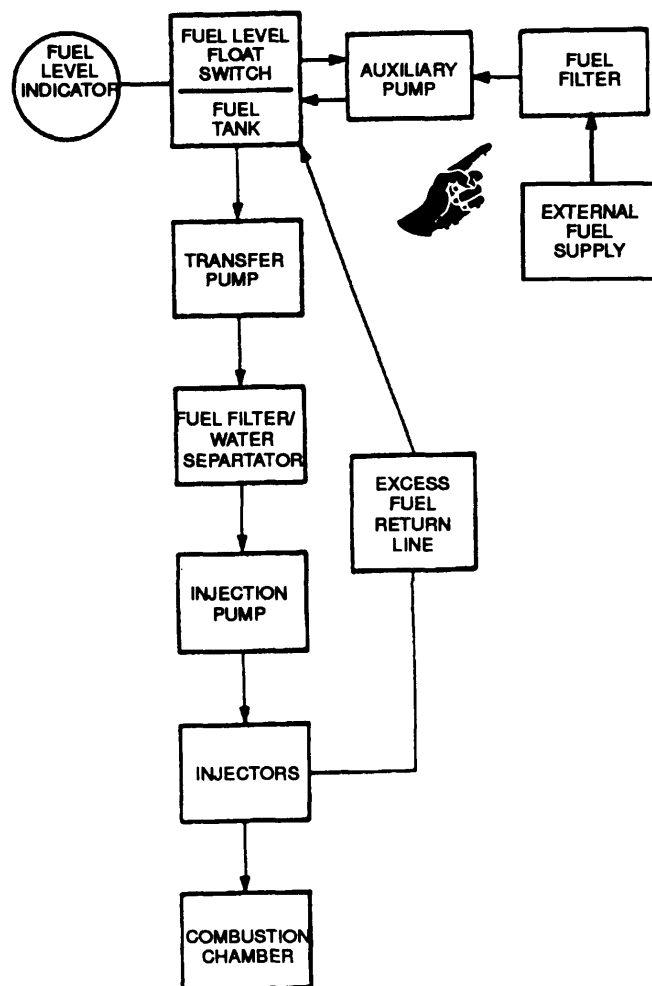

Figure 1-4. Fuel System

switch shuts off the auxiliary fuel pump when the generator fuel tank is full and reactivates the pump as the level drops. The FUEL LEVEL indicator indicates fuel level of generator fuel tank from (E) empty to (F) full in quarter tank increments.

1-13 ENGINE COOLING SYSTEM..

1-13.1 The Engine Cooling System (Figure 1-5) consists of a radiator, hoses, thermostat, water pump, a belt driven fan, cooling jackets and oil cooler. The water pump forces coolant through passages (cooling jackets) in the engine block and cylinder head where the coolant absorbs heat from the engine. When the engine reaches normal operating temperature, the thermostat opens and the heated coolant flows through the upper radiator hose assembly into the radiator. The cooling fan circulates air through the radiator where the coolant temperature is reduced.

1-13.2 A coolant high temperature switch provides automatic shut down in the event that coolant temperature exceeds $225 \pm 5^{\circ}\text{F}$ ($107 + 3^{\circ}\text{C}$). The COOLANT TEMP indicator indicates the engine coolant temperature, from 120°F to 240°F (48°C to 115°C).

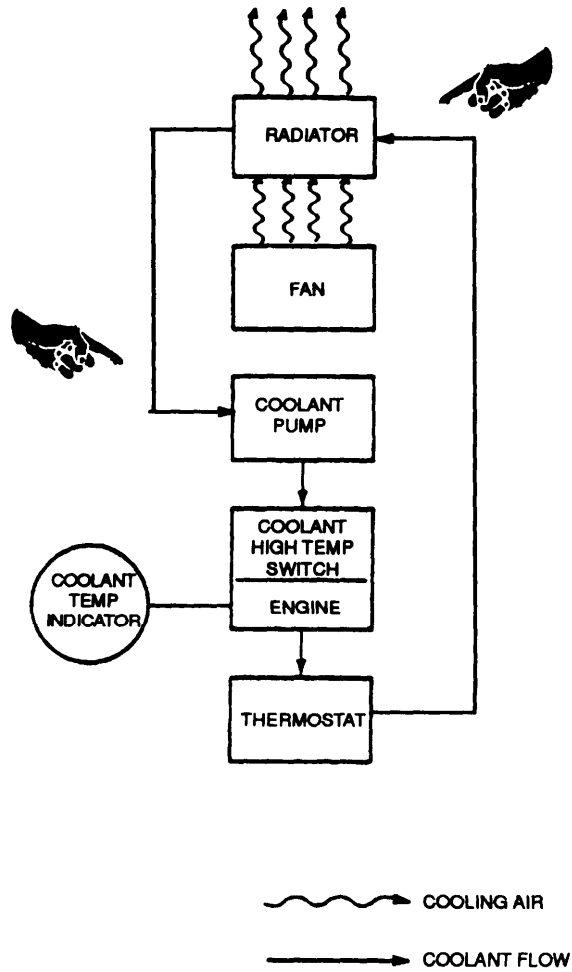

Figure 1-5. Engine Cooling System

1-14 LUBRICATION SYSTEM.

The Lubrication System (FIGURE 1-6) consists of an oil pan, dipstick, pump, oil pressure sender, AOAP sample valve, and filter. The oil pan is a reservoir for engine lubricating oil. The dipstick indicates oil level in the oil pan. A pump draws oil from the oil pan and through a screen removing large impurities. The oil then passes through a spin-on type filter where small impurities are removed. From the filter, oil enters the engine and is distributed to the engine's internal moving parts. After passing through the engine, the oil returns to the oil pan. The OIL PRESSURE indicator indicates oil pressure sensed by the oil pressure sender in the engine. The engine will shut off automatically if the oil pressure drops to a dangerously low level. The oil level can be checked with engine running.

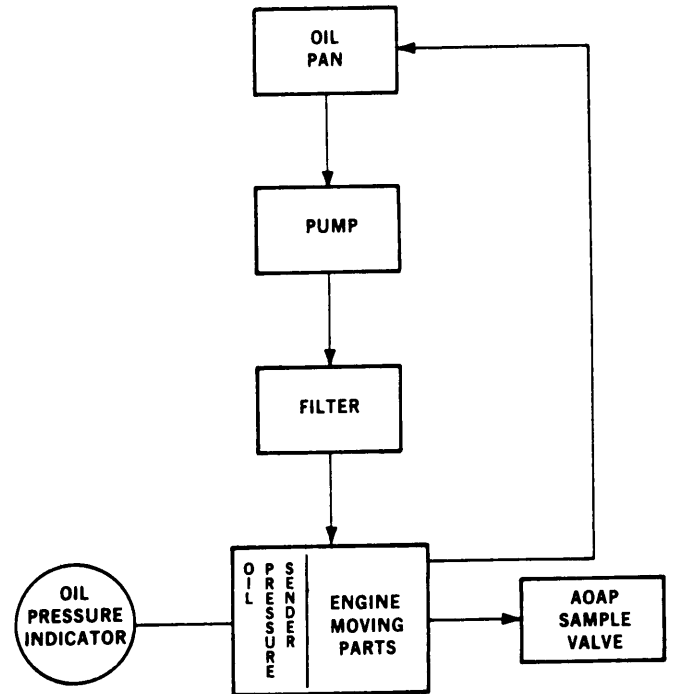

FIGURE 1-6. Engine Lubrication System

1-15 AIR INTAKE AND EXHAUST SYSTEM.

1-15.1 The Air Intake and Exhaust System (FIGURE 1-7), consists of an air cleaner assembly, intake manifold, turbocharger, exhaust manifold and muffler. Ambient air is drawn into the air cleaner assembly where it passes through the air cleaner element. Airborne dirt is removed and trapped in the element. A restriction indicator, located on the air cleaner assembly housing, displays red when the air cleaner element should be serviced. Dirt can be removed from the air cleaner housing by pinching an evacuator valve.

Filtered air is drawn out of the air cleaner assembly through air intake tubes to the turbocharger where it is forced into the intake manifold to the combustion chambers and mixed with fuel from the injectors.

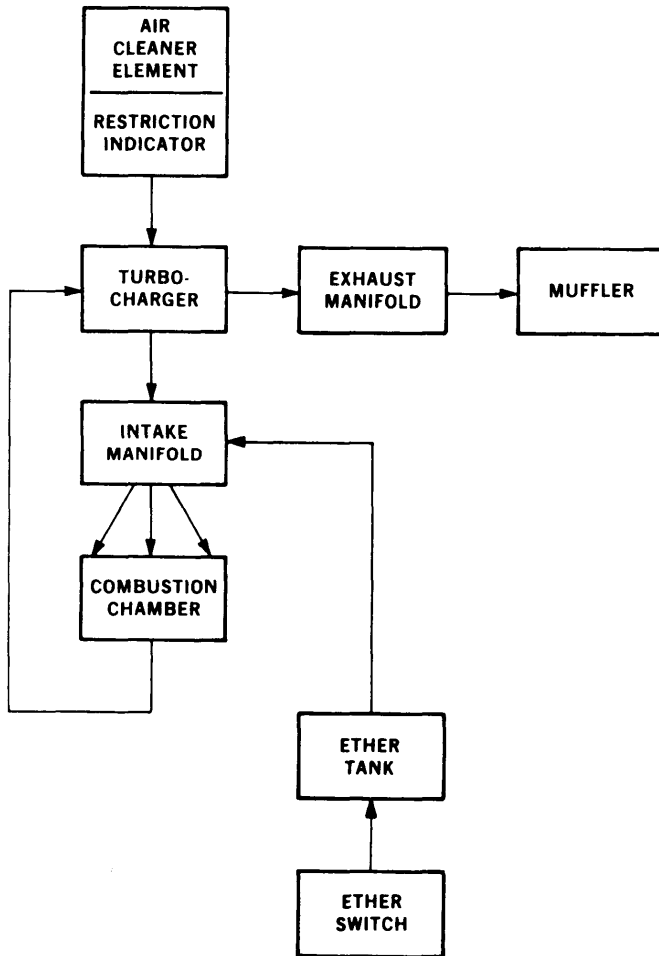

FIGURE 1-7. Air Intake and Exhaust System

1-15.2 The engine exhaust gases are released into the turbocharger. The exhaust gases drive the turbocharger forcing large amounts of air into the intake manifold. After passing through the turbocharger, the

exhaust gases are channeled into the muffler that deadens the sound of the exhaust gases. The gases pass from the muffler through the muffler outlet and are vented upward from the generator set housing.

1-15.3 Cold outside temperatures make starting the engine difficult. To improve engine starting, a cold weather starting aid has been provided that features an ether injection system. Ether is injected into the combustion chamber when the ETHER switch is ON and the MASTER SWITCH is in the START position.

1-16 OUTPUT SUPPLY SYSTEM.

1-16.1 The Output Supply System (FIGURE 1-8) consists primarily of the AC generator, the output load terminal board, the voltage reconnection terminal board, the AM-VM transfer switch and the AC circuit interrupter relay. Power created by the AC generator is supplied through the voltage reconnection terminal board and the AC circuit interrupter relay to the output load terminals on the output load terminal board. The voltage reconnection terminal board allows configuration of the generator set for 120/208 volt connections or 240/416 volt connections.

1-16.2 The AC CIRCUIT INTERRUPTER switch closes and opens the AC circuit interrupter relay. This enables or interrupts the power flow between the voltage reconnection terminal board and the output load terminals. The AC circuit interrupter relay is also opened

automatically during any of the specified set faults. The voltage regulator senses AC generator output voltage and provides control voltage to the AC generator exciter to maintain the desired AC generator output voltage. The position of the AM-VM transfer switch selects the output load terminals from which current and voltage are measured and are indicated on the AC voltmeter (VOLTS AC) and the ammeter (PERCENT RATED CURRENT).

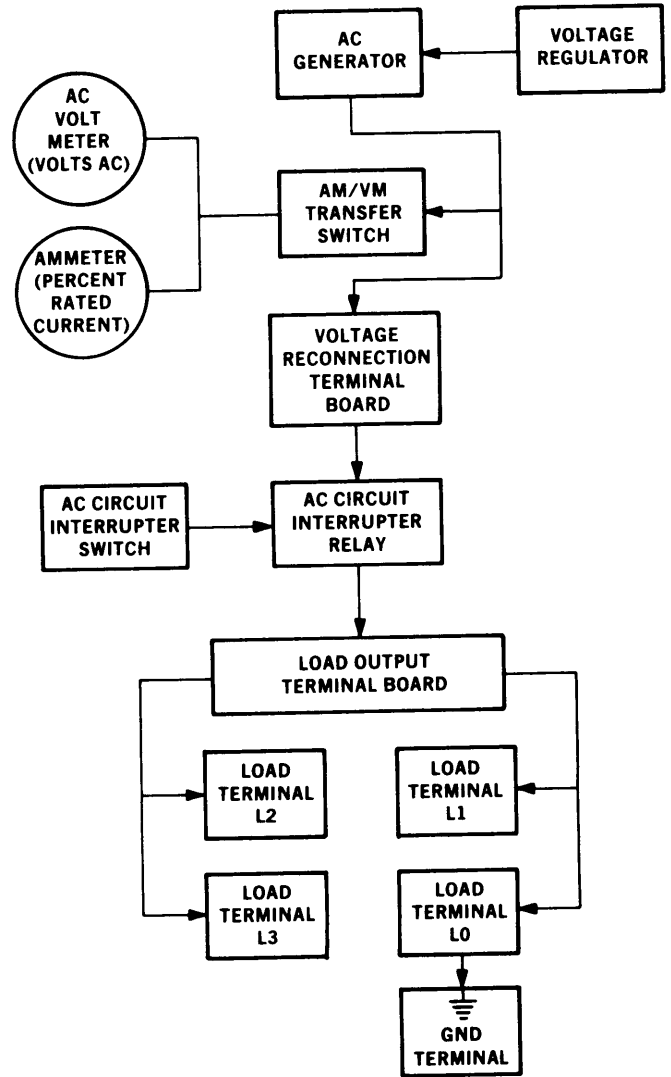

FIGURE 1-8. Output Supply System

CHAPTER 2

OPERATING INSTRUCTIONS

SECTION I. DESCRIPTION AND USE OF OPERATOR'S CONTROLS AND INDICATORS

2-1 GENERAL.

This section describes and illustrates the controls and indicators to ensure proper operation of the generator set.

2-2 CONTROL PANEL ASSEMBLY.

The control panel assembly contains most of the operating controls and indicators for the generator set. FIGURE 2-1 shows the control panel assembly layout and TABLE 2-1 describes each control and indicator.



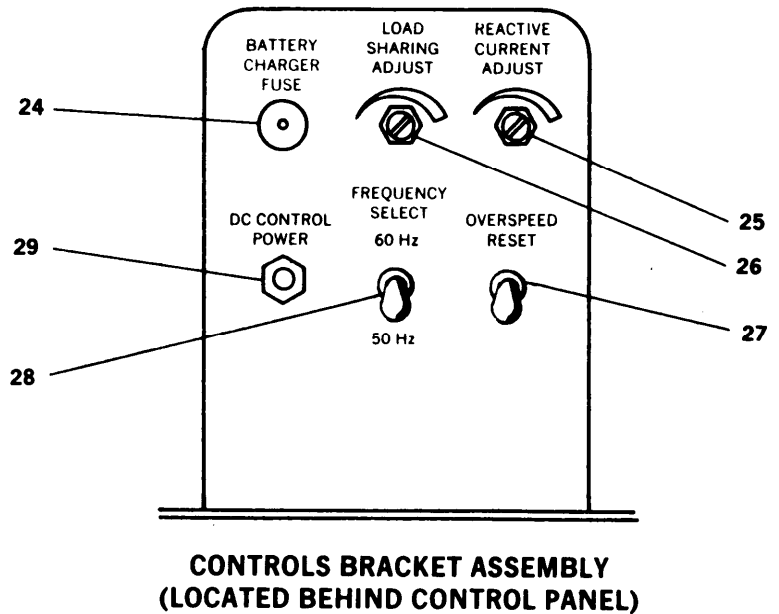
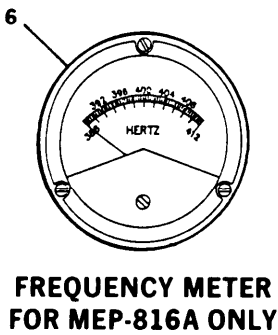
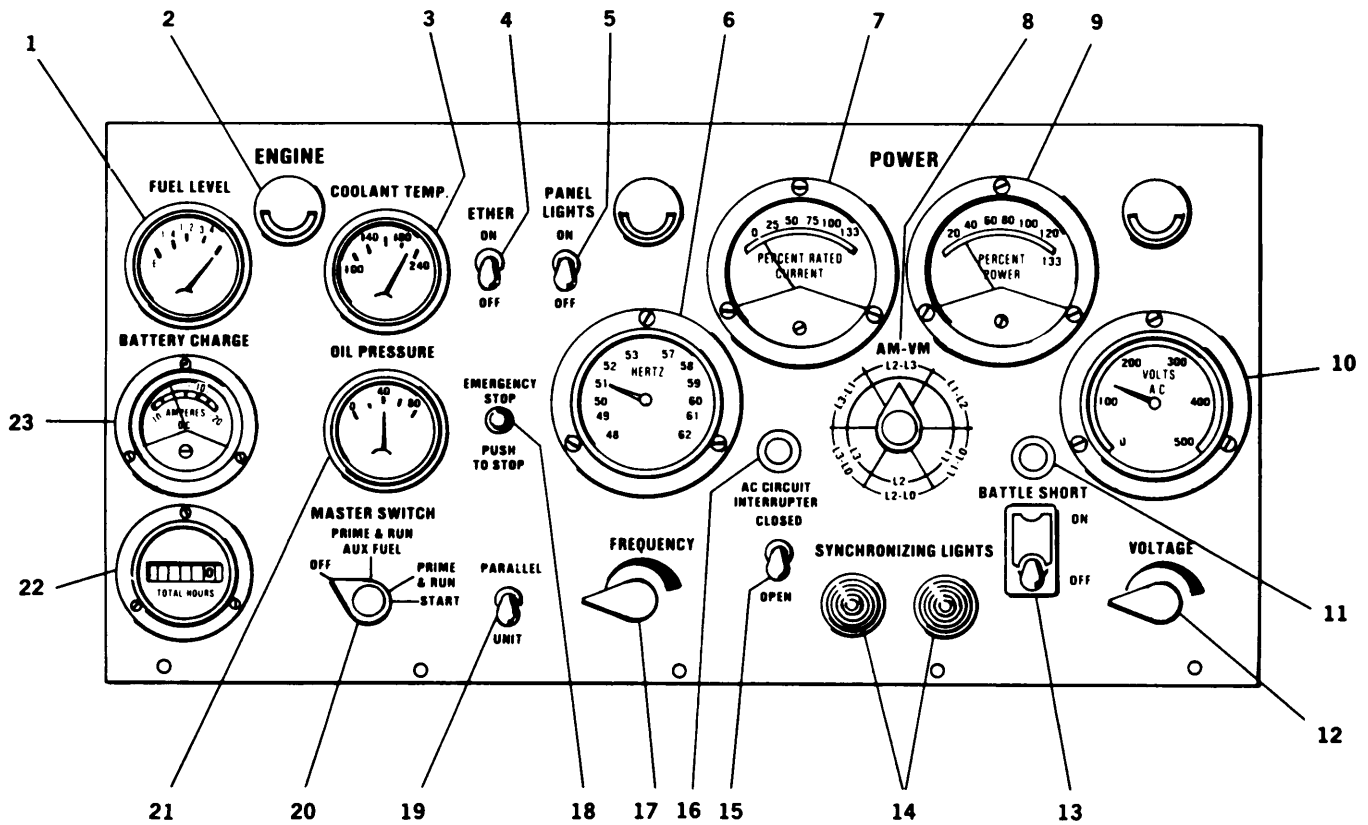

FIGURE 2-1. Control Panel/Controls Bracket Assembly

TABLE 2-1. Control Panel Controls and Indicators

Key	Control or Indicator	Function																					
1	FUEL LEVEL indicator	Indicates fuel level.																					
2	Panel lights	Illuminates control panel.																					
3	COOLANT TEMP. indicator	Indicates engine coolant temperature.																					
4	ETHER switch	Activates or deactivates cold starting aid system.																					
5	PANEL LIGHTS switch	Activates or deactivates panel lights.																					
6	FREQUENCY meter (HERTZ)	Indicates generator set output frequency.																					
7	Ammeter (PERCENT RATED CURRENT)	Indicates generator set load current as a percent of rated current.																					
8	AM-VM transfer switch	<p>Allows selection of current and voltage readings between output load terminals as follows:</p> <table style="margin-left: auto; margin-right: auto; border-collapse: collapse;"> <thead> <tr> <th style="text-align: left;"><u>Switch Position</u></th> <th style="text-align: left;"><u>Voltage</u></th> <th style="text-align: left;"><u>Current</u></th> </tr> </thead> <tbody> <tr> <td>L1-LO</td> <td>120* 240**</td> <td>L1</td> </tr> <tr> <td>L2-LO</td> <td>120* 240**</td> <td>L2</td> </tr> <tr> <td>L3-LO</td> <td>120* 240**</td> <td>L3</td> </tr> <tr> <td>L1-L2</td> <td>208* 416**</td> <td>None</td> </tr> <tr> <td>L2-L3</td> <td>208* 416**</td> <td>None</td> </tr> <tr> <td>L1-L3</td> <td>208* 416**</td> <td>None</td> </tr> </tbody> </table> <p>AC Reconnection Terminal Board Setting * 120/208 ** 240/416</p>	<u>Switch Position</u>	<u>Voltage</u>	<u>Current</u>	L1-LO	120* 240**	L1	L2-LO	120* 240**	L2	L3-LO	120* 240**	L3	L1-L2	208* 416**	None	L2-L3	208* 416**	None	L1-L3	208* 416**	None
<u>Switch Position</u>	<u>Voltage</u>	<u>Current</u>																					
L1-LO	120* 240**	L1																					
L2-LO	120* 240**	L2																					
L3-LO	120* 240**	L3																					
L1-L2	208* 416**	None																					
L2-L3	208* 416**	None																					
L1-L3	208* 416**	None																					
9	Kilowattmeter (PERCENT POWER)	Indicates generator set output power as a percent of rated power.																					
10	AC Voltmeter (VOLTS AC)	Indicates output voltage of generator set.																					
11	BATTLE SHORT light	Amber light indicates switch on.																					
12	VOLTAGE adjust Potentiometer	Adjusts generator set voltage.																					
13	BATTLE SHORT switch	Bypasses protective devices.																					

TABLE 2-1. Control Panel Controls and Indicators - Continued

Key	Control or Indicator	Function
14	SYNCHRONIZING LIGHTS	Indicates synchronization of units to be paralleled.
15	AC CIRCUIT INTERRUPTER switch	Opens or closes AC circuit interrupter relay.
16	AC CIRCUIT INTERRUPTER light	Green light indicates AC circuit interrupter is closed.
17	FREQUENCY adjust potentiometer	Adjusts frequency of generator set.
18	EMERGENCY STOP pushbutton	Shuts down generator set.
19	PARALLEL UNIT switch	Energizes or deenergizes paralleling circuits.
20	MASTER SWITCH	<p>OFF - Deenergizes all circuits, except panel lights.</p> <p>PRIME & RUN AUX FUEL - Energizes generator set run circuits with auxiliary fuel pump operating.</p> <p>PRIME & RUN - Energizes generator set run circuits with auxiliary fuel system deenergized.</p> <p>START - Energizes starter.</p>
21	OIL PRESSURE indicator	Indicates oil pressure.
22	Time meter (TOTAL HOURS)	Indicates total engine operating hours.
23	BATTERY CHARGE ammeter	Indicates charge/discharge rate of batteries.
24	BATTERY CHARGER FUSE (Located on controls bracket assembly)	Protects battery charging alternator from overload.
25	REACTIVE CURRENT ADJUST rheostat (Located on controls bracket assembly)	Adjusts current for load sharing requirements (maintenance personnel only).

TABLE 2-1. Control Panel Controls and Indicators - Continued

Key	Control or Indicator	Function
26	LOAD SHARING ADJUST rheostat (Located behind control panel)	Adjusts power for load sharing requirements (maintenance personnel only).
27	OVERSPEED RESET switch (Located on controls bracket assembly)	Resets generator set after an overspeed condition (maintenance personnel only).
28	FREQUENCY SELECT switch (MEP-806A only) (Located on controls bracket assembly)	Allows selection of 50 Hz or 60 Hz.
29	DC CONTROL POWER circuit breaker (Located on controls bracket assembly)	Energizes or deenergizes DC circuits.

2-3 MALFUNCTION INDICATOR PANEL.

The malfunction indicator panel (FIGURE 2-2) is located to the left of the control panel.

It contains a series of lights which indicate a generator set failure or abnormal operating condition. TABLE 2-2 describes each indicator light.

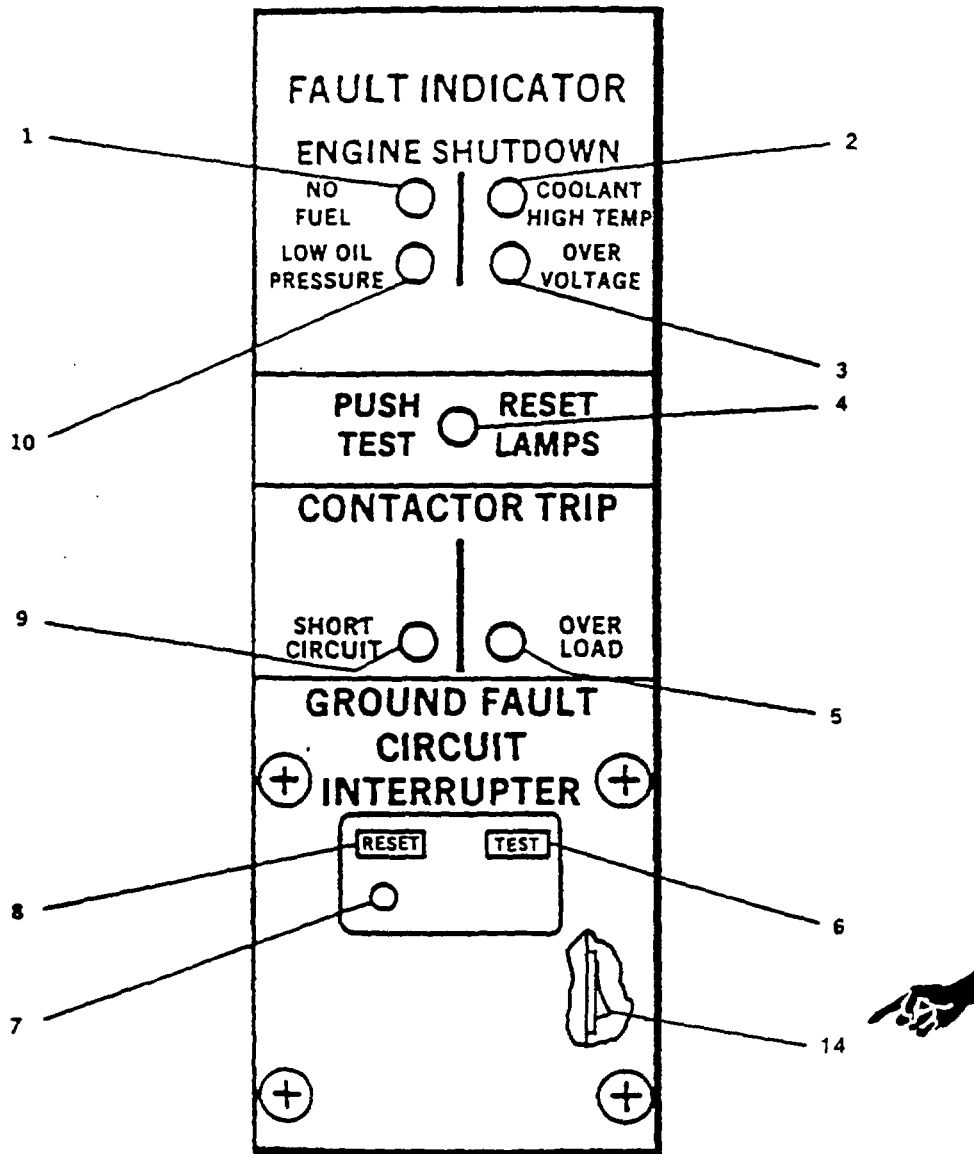

FIGURE 2-2. Malfunction Indicator Panel

TABLE 2-2. Malfunction Indicator Panel

KEY	CONNECTOR	FUNCTION
1	NO FUEL indicator	Lights when fuel level in fuel tank is below preset level.
2	COOLANT HIGH TEMP	Lights when engine coolant indicator temperature exceeds $2250 + ^\circ\text{F}$ (107 ± 30 F).
3	OVERVOLTAGE indicator	Lights when voltage in 120 volt generator coil exceeds $153 + 3$ volts.
4	OVERSPEED indicator	Lights when engine speed exceeds $22d0 \pm 40$ RPM.
5	REVERSE POWER indicator	Lights when power flow into generator set exceeds $20 + 3$ percent of rated current.
6	OVER LOAD indicator	Lights when current in any phase exceeds 110 percent of rated current.
7	GROUND FAULT CIRCUIT INTERRUPTER TEST Pushbutton	Tests GROUND FAULT CIRCUIT INTERRUPTER.
8	GROUND FAULT CIRCUIT INTERRUPTER	Indicates a ground fault condition. indicator
9	GROUND FAULT CIRCUIT INTERRUPTER RESET Pushbutton	Rests GROUND FAULT CIRCUIT INTERRUPTER.
10	SHORT CIRCUIT indicator	Lights when generator set output in any phase exceeds $425 + 25$ percent of rated current.
11	UNDER VOLTAGE indicator	Lights when voltage in 120 volt generator coil winding drops below 99 ± 4 VAC.
12	PUSH TEST RESET LAMPS switch	Tests and resets fault indicator lamps.
13	LOW OIL PRESSURE indicator	Lights when engine lubrication systems pressure is less than $15 + 3$ psi ($103.4 + 20.7$ kPa) during engine operation.
14	Convenience Receptacle Overload Circuit Breaker (10-amp in-line fuse on generator sets,	Circuit breaker trips on when load on convenience receptacle exceeds 10 amps (fuse blows on generator sets, contract number DAAK01-88-D-D082). contract number DAAK01-88-D-D082)

SECTION II. PREVENTIVE MAINTENANCE CHECKS AND SERVICES (PMCS)

2-4 GENERAL.

To ensure that the generator set is ready for operation at all times, it must be inspected so that defects can be discovered and corrected before they result in serious damage or failure.

2-4.1 Before You Operate. Always keep in mind the CAUTIONS and WARNINGS. Perform your before (B) PMCS.

2-4.2 While You Operate. Always keep in mind the CAUTIONS and WARNINGS. Perform your during (D) PMCS.

2-4.3 After You Operate. Be sure to perform your after (A) PMCS.

2-4.4 If Your Equipment Fails to Operate If your equipment does not perform as required, refer to Chapter 3 under Troubleshooting for possible problems. Report any malfunctions or failures on DA Form 2404, refer to DA PAM 738-750.

2-5 PMCS PROCEDURES.

NOTE

For general location of items to be inspected in TABLE 2-3, refer to FIGURE 1-2 and FIGURE 2-1.

2-5.1 Purpose of PMCS Table. Your Preventive Maintenance Checks and Services (TABLE 2-3) list the inspections and care of your equipment required to keep it in good operating condition.

2-5.2 Purpose of Service Intervals. The internal column of your PMCS table tells you when to do a certain check or service.

2-5.3 Special Instructions. The following guidelines have been provided to help you in classifying leaks observed while performing PMCS.

Class I. Seepage of fluid (as indicated by wetness or discoloration) not great enough to form drops.

Class II. Leakage of fluid great enough to form drops but not enough to cause drops to drip from item being checked/inspected.

Class III. Leakage of fluid great enough to form drops that fall from the item being checked/inspected.

CAUTION

Equipment operation is allowable with minor oil and coolant leakage (Class I or II).

Of course, you must consider the fluid capacity in the item/system being checked/inspected. When in doubt, notify the next higher level of maintenance.

When operating with Class I or Class II leaks, continue to check fluid levels as required in your PMCS. All leaks should be reported to the next higher level of maintenance.

2-5.4 Procedures Column The procedures column of your PMCS table tells you how to do the required checks and services. Carefully follow these instructions. If you do not have the tools, or if the procedures indicate, complete a DA Form 2404 and submit it to the next higher level of maintenance.

2-5.5 The “Equipment is not ready/available if”. This column tells you when and why the generator set cannot be used.

NOTE

The terms ready/ available and mission capable refer to the same status: Generator set is on hand and is able to perform its combat missions, refer to DA PAM 738-750.

2-5.6 Reporting and Correcting Deficiencies. If your generator set does not perform as required, refer to Chapter 3 under Troubleshooting for possible problems. Report any malfunctions or failures on DA Form 2404, refer to DA PAM 738-750.

2-5.7 Removal of Assemblies/Equipment to Perform PMCS. There is no requirement to remove assemblies/equipment prior to performing the PMCS.

Table 2-3. Operator Preventive Maintenance Checks and Services

NOTE

If the equipment must be kept in continuous operation, check and service only those items that can be checked and serviced without disturbing operation. Make the complete checks and services when the equipment can be shut down

NOTE

The generator set can be operated continuously at any load from no load up to and including rated load: However, at light loads (less than 25% of set rating) an oily residue (unburned fuel oil) may occasionally be noticed in the exhaust system outlet and around connection joints in the exhaust system. This residue is caused by the inability of the fuel injection system to consistently meter the small amount of fuel required to operate at these low load levels and is not a defect in the fuel system. The oily residue could affect engine performance and create a cosmetic problem on and around the generator set. Operation at rated load will bum off this oily residue. The length of time required at rated load depends on the amount of residue. The muffler may also need to be removed and cleaned if excessive build up occurs. This oily residue can be prevented by increasing the electrical load on the set.

Item No.	Interval			Item to be Inspected	Procedures: Check for and have repaired or adjusted as necessary	Equipment Is Not Ready/ Available If:
	B-BERORE	D-DURING	A-AFTER			
1.	•	•	•	.Housing	GENERATOR SET Check doors, panels, hinges, and latches for damaged, loose or corroded items. Inspect air intake and exhaust grills for debris.	Cannot secure doors.
2.	•		•	Identification plates	Check to ensure identification plates are secure.	Skid base is cracked or shows signs of structural damage.
3.	•		•	Skid Base	Inspect skid base for cracks or corrosion.	
4.	•			Acoustical Materials	Ensure that acoustical materials are free of damage or not missing.	

TABLE 2-3. Operator Preventive Maintenance Checks and Services -
 Continued

Item No.	B - BEFORE			Item to be inspected	D - DURING Procedures Check for and have repaired or adjusted as necessary	A - AFTER Equipment is not ready/available if:
	Internal	B	D			
5	●	●	●	ENGINE COMPARTMENT Engine Assembly	<p style="text-align: center;"><u>WARNING</u></p> <p>With any access door open, the noise level of this generator set when operating could cause hearing damage. Hearing protection must be worn when working near the generator set while running.</p> <p style="text-align: center;"><u>WARNING</u></p> <p>The fuels in this generator set are highly explosive. DO NOT smoke or use open flame when performing maintenance. Flames and explosion can occur resulting in severe personal-injury or death.</p> <p>Check for loose damaged or missing hardware.</p>	

TABLE 2-3. Operator Preventive Maintenance Checks and Services -
 Continued

Item No.	B - BEFORE			Item to be inspected	D - DURING Procedures Check for and have repaired or adjusted as necessary	A - AFTER Equipment is not ready/ available if:
	B	D	A			
6	●	●	●	Fuel System	Inspect fuel system for leaks, damaged, loose or missing parts.	Any fuel leaks, damaged, loose or missing parts
7	●		●	Fuel Filter/ Water Separator	Inspect fuel filter/ water separator for leaks, proper mounting, cracks, damage, or missing parts. Drain water from fuel filter/ water separator.	Any fuel leaks. Fuel filter/ water separator not drained.
8	●			Ether Start System	Check for deteriorated, loose or missing parts.	
9	●	●	●	Lubrication System	Inspect lubrication system for leaks, damaged, loose or missing parts. Check engine oil level. Check engine oil for contamination.	Oil leaks at Class III. Damaged, loose or missing parts. Oil level is below oil level. Engine oil shows signs of contamination.

TABLE 2-3. Operator Preventive Maintenance Checks and Services -
 Continued

Item No.	Interval			Item to be inspected	Procedures Check for and have repaired or adjusted as necessary	Equipment is not ready/available if:
	B - BEFORE	D - DURING	A - AFTER			
					<u>WARNING</u>	
				COOLING SYSTEM		
10	●		●	Radiator	Check radiator for leaks, damage or missing parts.	Class III leaks. Radiator cap missing.
11	●		●	Hoses	Check hoses for leaks or cracks.	Class III leaks.
12	●			Cooling Fan	Check fan for damage or looseness.	Cooling fan is damaged or loose.
		●			Check for unusual noise being emitted from fan area.	
13	●		●	Fan Belts	Inspect belts for cracks, fraying and looseness.	Broken belt(s).

TABLE 2-3. Operator Preventive Maintenance Checks and Services -
 Continued

Item No.	B - BEFORE			Item to be inspected	D - DURING Procedures Check for and have repaired or adjusted as necessary	A - AFTER Equipment is not ready/available if:
	Interval	E	D			
14		●		●	Over-flow Bottle Check over-flow bottle for leaks or missing parts. Check coolant level.	Class III leaks. Coolant level is at cold line.
15		●			Exhaust System Check muffler for leaks and exhaust system for corrosion, damaged, or missing parts.	Muffler or exhaust system damaged or leaking.
16		●			Air Cleaner Assembly Inspect air cleaner assembly and piping for loose or damaged connections. Check restriction indicator for clogged element. <u>WARNING</u> Battery acid can cause burns to unprotected skin. <u>WARNING</u> Batteries give off flammable gas. Do not smoke or use open flame when performing maintenance. Flames and explosion could result in personal injury or death.	Clogged element is indicated or piping and connections are loose.

TABLE 2-3. Operator Preventive Maintenance Checks and Services -
 Continued

Item No.	Interval			Item to be inspected	Procedures Check for and have repaired or adjusted as necessary	Equipment is not ready/available if:
	B - BEFORE	D - DURING	A - AFTER			
17	●			Batteries	Check electrolyte level.	
18	●			Battery Cables	Inspect cables and connectors for corrosion, loose, damaged or missing parts.	Cables are loose, damaged or missing.
					<u>WARNING</u>	
					High voltage is produced when this generator set is in operation. Improper operation could result in personal injury or death.	
19	●			Output Box Assembly	Check for loose or damaged wiring or cables.	Loose or damaged wiring or cables.
					Check output terminals for damaged or missing hardware.	Damaged or missing hardware.
				CONTROL BOX ASSEMBLY		
20	●		●	Indicators and Controls	Check all indicators and controls for damaged or missing parts.	Indicators or controls damaged or missing.
		●			Ensure all indicators are operating properly.	Frequency or AC Voltmeter inoperative.

TABLE 2-3. Operator Preventive Maintenance Checks and Services -
 Continued

Item No	B - BEFORE			Item to be inspected	D - DURING	A - AFTER
	Interval	B	D			
21		●		Control Box Harness	Check for loose or damaged wiring.	Loose or damaged wires.
22		●		Parallel Cable	If required for generator set operation, inspect parallel cable for damage. <p style="text-align: center;"><u>WARNING</u></p> ENSURE generator set is properly grounded prior to starting. Otherwise serious injury or death could result by electrocution.	
23		●	●	Ground Rod Cable and Connection	Inspect ground rod and cable for loose-connections, breaks, damage and corrosion.	Cable is missing or damaged.

SECTION III. OPERATION UNDER USUAL CONDITIONS

2-6 GENERAL. This section provides information and guidance for generator set operation under normal conditions, refer to FM 20-31.

2-7 ASSEMBLY AND PREPARATION FOR USE.

2-7.1 Installation of Ground Rod.

WARNING

Do not operate the generator set until it has been connected to a suitable ground. Serious injury or death can result from operating an ungrounded generator set.

- a. Insert ground cable (2, FIGURE 2-3) through slot on load output terminal board terminal marked GND (1). Tighten terminal nut.
- b. Connect coupling (5) to ground rod (4) and screw driving stud (3) into coupling (5). Make sure that driving stud (3) seats on ground rod (4).
- c. Drive ground rod into ground until coupling is just above surface.
- d. Remove driving stud and install another section of ground rod.
- e. Install another coupling (5) and driving stud (3). Drive ground rod down until new coupling is just above ground surface.

f. Repeat steps d and e until ground rod has been driven eight feet or deeper, providing an effective ground.

g. Connect clamp (6) and ground cable (2) to ground rod (4) and tighten clamp screw.

2-7.2 Installation of Load Cables.

WARNING

Never attempt to connect or disconnect load cables while the generator set is running. Failure to observe this warning could result in severe personal injury or death by electrocution.

CAUTION

Do not connect the load cables to the convenience receptacle. Failure to observe this caution can result in damage to the generator set.

- a. Shutdown generator set.
- b. Select required output terminals from TABLE 2-4.
- c. Open output load terminal door.

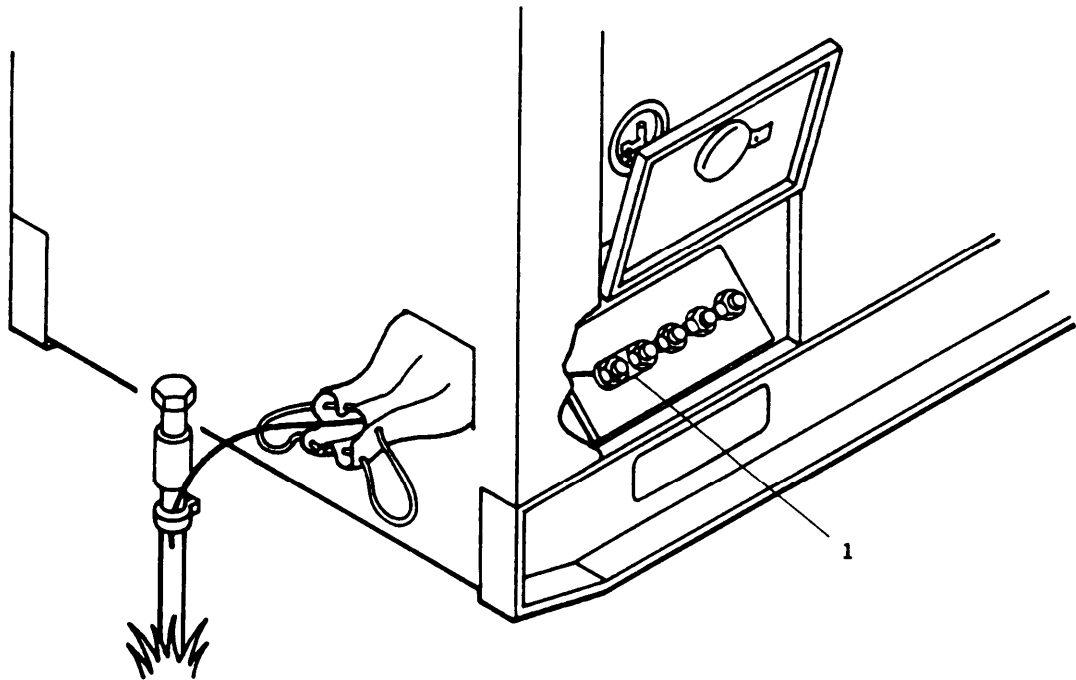
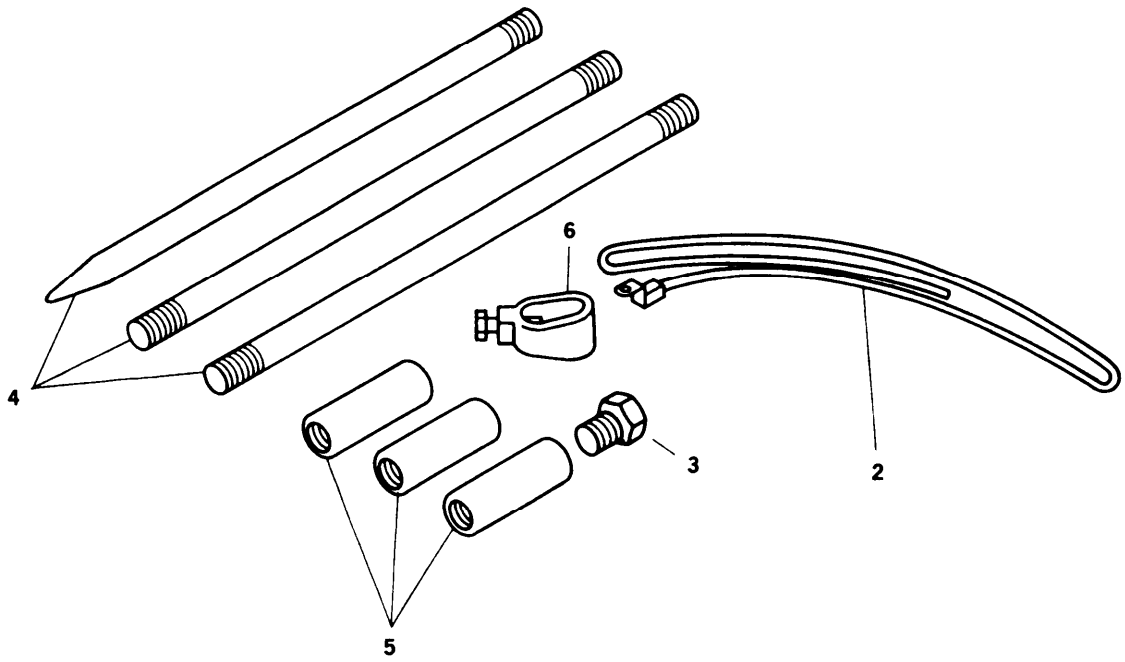

FIGURE 2-3. Grounding Connections

- d. Using terminal nut wrench (3, FIGURE 2-4) loosen terminal nuts (1) on terminals (2) selected in Step b.
- g. Secure wrench (3) in bracket inside load terminal board door, and close door.

CAUTION

- e. Insert ends of load cables through load cable entrance box. Insert ends of cables into slots of load terminal studs (2).
- f. Tighten load terminal nuts (1).
- When using single phase connections, always attempt to balance loads between terminals (do not connect all loads between one terminal and LO). Failure to observe this caution can result in damage to generator set.

TABLE 2-4. Load Terminal, AC Reconnection Board and AM-VM Transfer Switch Selection

RECONNECTION BOARD POSITION	TERMINALS	AM-VM TRANSFER SWITCH POSITION	VOLTAGE READING	CURRENT READING (TERMINAL)
120/208	L1, L2, L3, LO 3 PHASE. (SINGLE PHASE LOADS CAN BE SERVED USING ANY TERMINAL TO LO)	L1 -LO L2 -LO L3-LO L1-L2 L2-L3 L3-L1	120 VOLTS 120 VOLTS 120 VOLTS 208 VOLTS 208 VOLTS 208 VOLTS	L1 L2 L3 NONE NONE NONE
240/416	L1, L2, L3, LO 3 PHASE. (SINGLE PHASE LOADS CAN BE SERVED USING ANY TERMINAL TO LO)	L1-LO L2-LO L3-LO L1-L2 L2-L3 L3-L1	240 VOLTS 240 VOLTS 240 VOLTS 416 VOLTS 416 VOLTS 416 VOLTS	L1 L2 L3 NONE NONE NONE

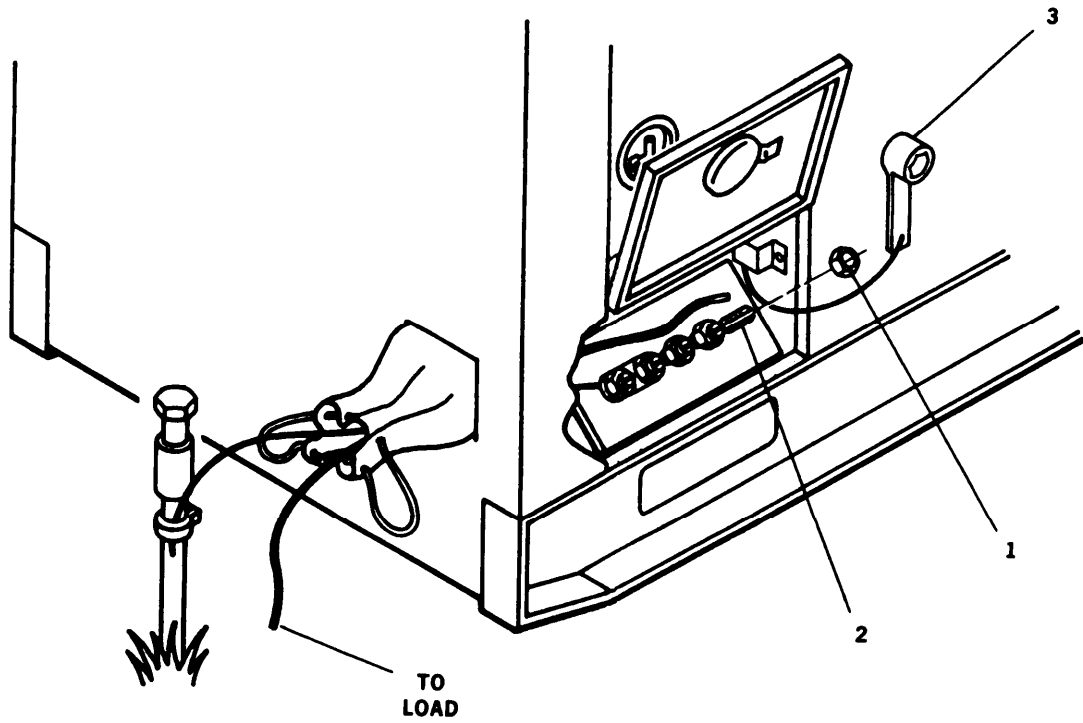

FIGURE 2-4. Installation of Load Cables

2-8 INITIAL ADJUSTMENTS, DAILY CHECKS AND SELF TEST.

2-8.1 Perform all before (B) PMCS, refer to Table 2-3.

2-8.2 Initial Adjustments.

- a. Place DEAD CRANK switch in NORMAL position.
- b. Push DC CONTROL POWER circuit breaker in.
- c. Place FREQUENCY SELECT switch to required position (MEP-806A).
- d. Ensure voltage reconnection terminal board is positioned to match voltage requirements. If voltage reconnection terminal board must be changed, notify next higher maintenance level.
- e. Place AM-VIM transfer switch in a position corresponding to output terminal load connections, refer to Table 2-4.
- f. Place PARALLEL UNIT switch in UNIT position.
- g. Pull out EMERGENCY STOP switch.

2-8.3 Self Test.

- a. Place MASTER SWITCH to PRIME AND RUN position.
- b. Push PRESS TO TEST pushbutton on malfunction indicator panel. Ensure all indicator lights are lit. When PRESS TO TEST pushbutton is released, all lights should go out.
- c. Press BATTLE SHORT press to test light on the control panel assembly. Ensure indicator light is lit. When press to test light is released, light should go out.
- d. Press AC CIRCUIT INTERRUPTER press to test light on the control panel assembly. Ensure indicator light is lit. When press to test light is released light should go out.

2-9 OPERATING PROCEDURE.

WARNING

High voltage is produced when generator set is in operation. Improper operation could result in personal injury or death.

WARNING

Exhaust discharge contains deadly gases. Do not operate the generator set in enclosed areas unless exhaust discharge is properly vented outside. Severe personal injury or death due to carbon monoxide poisoning could result.

NOTE

If generator set is to be operated in parallel with another unit, refer to PARALLEL UNIT OPERATION, paragraph 2-10.

2-9.1 Starting Procedure

WARNING

Never attempt to start the generator set if it has not been properly grounded. Failure to observe this warning could result in serious injury or death by electrocution.

CAUTION

Do not crank engine in excess of fifteen seconds. Allow starter to cool at least fifteen seconds between attempted starts. Failure to observe this caution could result in damage to the starter.

NOTE

At temperatures below 40°F (4°C) it may be necessary to use the cold weather starting aid.

NOTE

Ensure all generator set access doors, except control panel access door, are closed.

- a. Rotate MASTER SWITCH to START position.
- b. In cold weather conditions, push ETHER switch to ON position as required, until engine accelerates to governed speed.
- c. Hold MASTER SWITCH in START position until oil pressure reaches at least 25 psi (172 kPa), voltage has increased to its approximate rated value, and engine has reached stable operating speed.
- d. Release MASTER SWITCH to PRIME AND RUN position.
- e. If operating with an auxiliary fuel source, rotate MASTER SWITCH to PRIME AND RUN AUX FUEL position.
- f. Check COOLANT TEMP [170-200°F (77-93°C)] and OIL PRESSURE [25-60 psi (172-414 kPa)] indicators for normal readings.
- g. Turn VOLTAGE and FREQUENCY adjust potentiometers to required values for voltage and frequency.
- h. Press GROUND FAULT CIRCUIT INTERRUPTER TEST pushbutton. Ensure indicator window is clear. Press RESET pushbutton and ensure indicator is red.
- i. Place AC CIRCUIT INTERRUPTER switch to CLOSED position.
- j. Ensure voltage and frequency are still at rated values. Adjust if necessary.
- k. Rotate AM-VM transfer switch to each phase position while observing ammeter (PERCENT RATED CURRENT) . If more than rated load is indicated in any phase, reduce load.

NOTE

Warm up engine without load for five minutes. (If required, load can be applied immediately) .

- l. Check kilowattmeter (PERCENT POWER). If indication is more than 100 percent rated load, reduce load.

WARNING

With any access door open, the noise level of this generator set when operating could cause hearing damage. Hearing protection must be worn when working near the generator set while running.

- m. Perform all DURING (D) OPERATION PMCS requirements in accordance with TABLE 2-3.

2-9.2 Stopping Procedure.

- a. Place AC CIRCUIT INTERRUPTER switch in OPEN position.
- b. Allow generator set to operate five minutes with no load applied.
- c. Place MASTER SWITCH in OFF position.
- d. Perform all AFTER (A) OPERATION PMCS requirements in accordance with TABLE 2-3.
- e. Place DEAD CRANK switch in OFF position.

2-10 PARALLEL UNIT OPERATION (LOAD SHARING).

CAUTION

Ensure generator sets are the same size and mode before attempting parallel operation.

2-10.1 General. The following method of parallel operation will be used to share the load between two generator sets. Refer to FIGURE 2-1 for location of operator controls and indicators mentioned below and FIGURE 2-5 for proper paralleling configuration.

2-10.2 Pre-Operation.

WARNING

Prior to making any connections for parallel operation, ensure that there is no input to the load and that the generator sets are shut down. Failure to observe this warning can result in injury or death by electrocution.

- a. Ensure that load requirement is equal or below the combined rated capacity of the two generator sets.

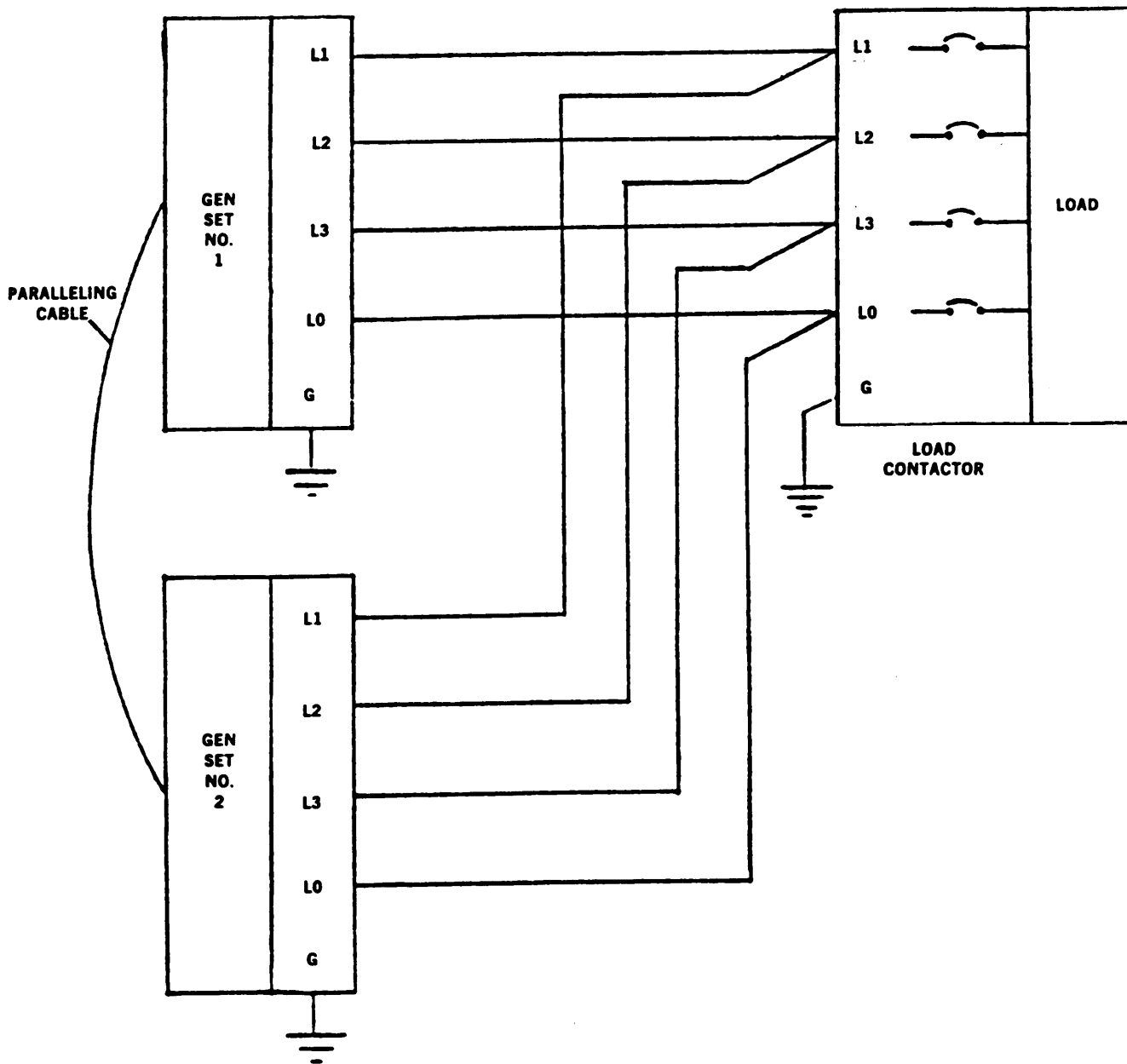

FIGURE 2-5. Parallel Operation Setup

WARNING

Never attempt to start the generator set if it is not properly grounded. Failure to observe this warning could result in serious injury or death by electrocution.

- b. Determine voltage requirements of load and position voltage reconnection terminal boards of the two generator sets to the required voltage connection. Ensure FREQUENCY SELECT switch (MEP-806A) for both generators are positioned for the same load requirements.
- c. Identify one generator set as No. 1 and the other as No. 2.
- d. Remove paralleling cable from storage box located inside battery compartment access door.

- e. Connect the paralleling cable between the two generator sets. Connect the generator sets to the load observing the proper phase polarity.

CAUTION

Do not close the AC CIRCUIT INTERRUPTER switch on either of the generator sets, nor close the load contactor at load until specifically directed to do so. Closing any of these devices at any other time may severely damage one or both of the generator sets.

2-10.3 Operation.

- a. Start each generator set, refer to paragraph 2-9.1.
- b. Rotate both VOLTAGE adjust potentiometers to obtain the same voltage indication on each set.

c. Rotate both FREQUENCY adjust potentiometers to obtain the same frequency indication on both sets. Ensure load contactor at load is open.

d. Position and hold AC CIRCUIT INTERRUPTER switch, on generator set No. 1, to CLOSED until indicator lights.

e. Place the UNIT-PARALLEL switch on both units in PARALLEL position.

CAUTION

If synchronizing lights on generator set No. 2 do not glow bright and dark in unison, the phasing is wrong. Shut down generator sets and check that load cables are connected properly. Failure to observe this caution can result in damage to generator sets.

f. Observe synchronizing lights on generator set No. 2. The lights should be glowing bright and dark in unison.

g. Adjust frequency of generator set No. 2 until synchronizing lights glow bright and dark in unison at 2 to 3 second internals.

CAUTION

Check that load contactor at load is open before attempting to place generators on the line. Failure to observe this caution can result in damage to generator sets.

h. When both synchronizing lights are dark, position and hold AC CIRCUIT INTERRUPTER switch of generator set No. 2 to the CLOSED position until indicator lights.

NOTE

The generator sets are now operating in parallel with no load.

i. Rotate FREQUENCY adjust potentiometer of generator set No. 1 until kilowattmeter (PERCENT POWER) indicates approximately "0".

- j. Rotate the VOLTAGE adjust potentiometer of generator set No. 1 until ammeter (PERCENT RATED CURRENT) reads approximately "0".
- k. Close the load contactor at the load.

NOTE

If the REVERSE POWER indicator of either generator set lights, and the AC Circuit Interrupter relay opens, open the load contactor at load and de-synchronize the generator sets. (Repeat the necessary steps d through k above.)

- l. Compare ammeter (PERCENT RATED CURRENT) readings of both generator sets. If readings are not within 10 percent, notify next higher level of maintenance.
- m. Compare kilowatt-meter (PERCENT POWER) readings of both generator sets. If readings are not within 10 percent, notify next higher level of maintenance.

2-10.4 Removal from Parallel Operation.

WARNING

If necessary to move a generator set which has been operating in parallel with another generator set, shut down remaining generator set connected to the load, prior to removing load cables or ground. Failure to observe this warning can result in injury or death by electrocution.

CAUTION

Prior to removal of generator set from parallel operation, make sure load does not exceed full load rating of generator set remaining on the line. Failure to observe this caution can result in damage to generator set.

- a. Position AC CIRCUIT INTERRUPTER switch to OPEN until indicator goes out.
- b. Return UNIT-PARALLEL switch to UNIT position.

- c. Refer to paragraph 2-9.2 to stop generator set.

2-11 PREPARATION FOR MOVEMENT .

- a. Shut down generator set. Refer to paragraph 2-9.2. If generator set is operating in parallel refer to paragraph 2-10.4
- b. Disconnect load cables.
- c. Disconnect paralleling cable, if used, and store in storage box.
- d. When using auxiliary fuel line, disconnect line, drain excess fuel from line and store line in storage box.

- e. Disconnect ground cable and remove ground rods. Store ground rods in holding clips located inside housing left side generator set. Store cable and couplings in storage box.
- f. Secure all generator set access doors and panels.
- g. For assembly and preparation for use, refer to paragraph 2-7.

2-12 OPERATING INSTRUCTIONS ON PLATES .

There are identification and instruction plates on the generator set. Figure 2-6 through Figure 2-20 show the location and contents of each plate on the generator set.

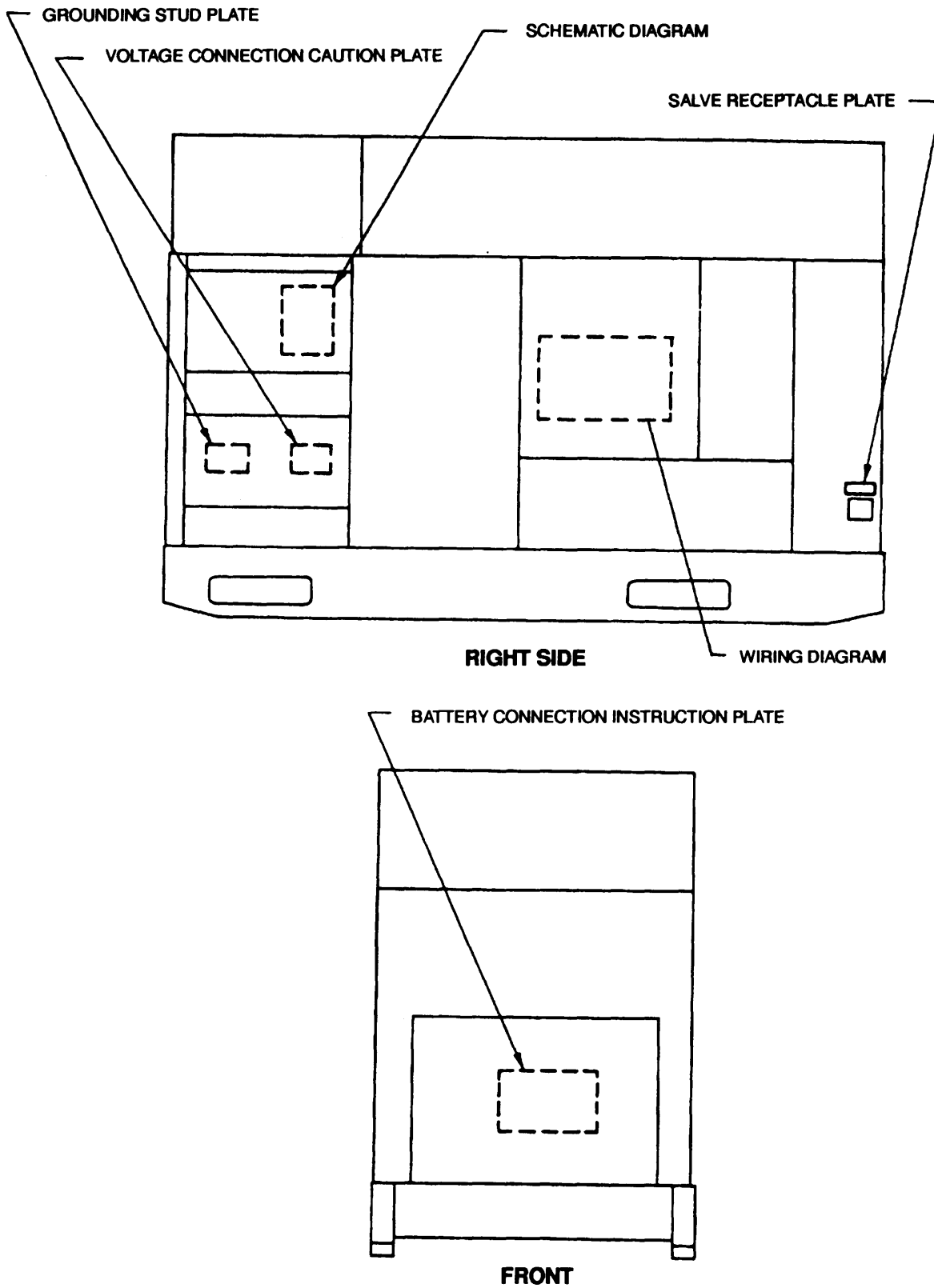

Figure 2-6. Operating Instructions Plates (Front and Right Side)

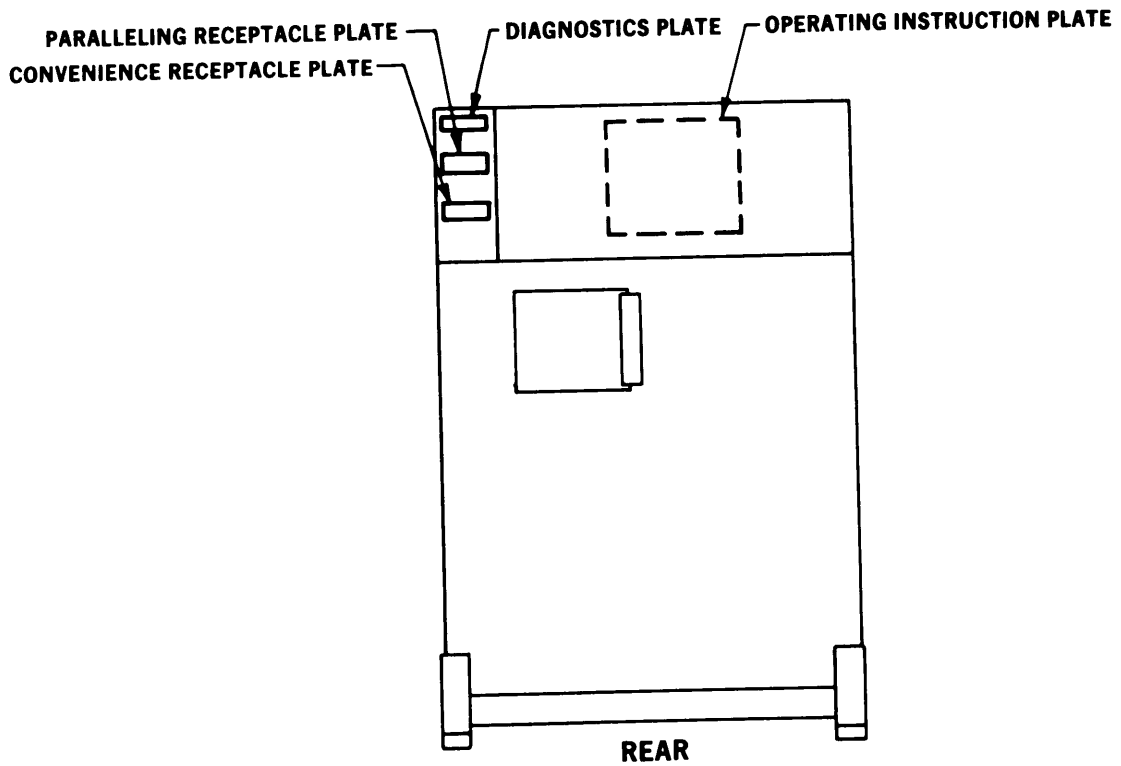
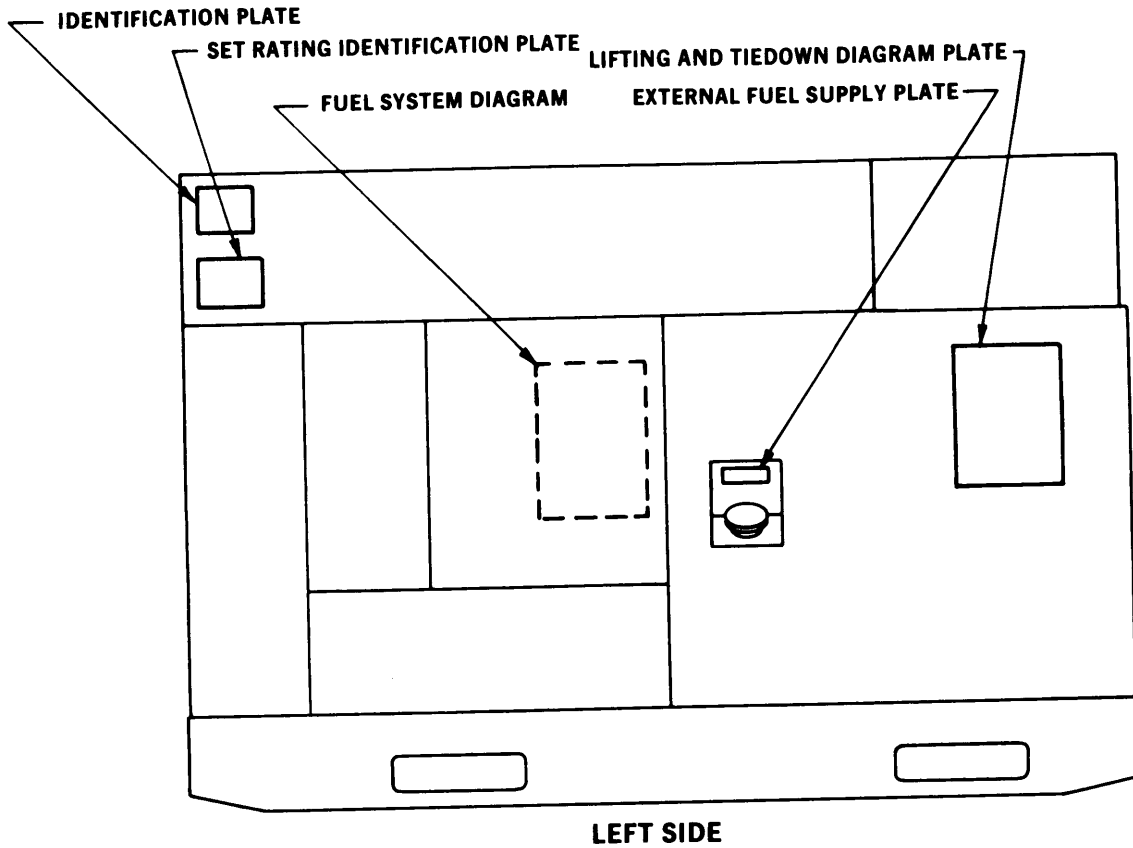

FIGURE 2-7. Operating Instructions Plates (Rear and Left Side)

OPERATING

- WARNING:**
- A. TO AVOID SHOCK HAZARD SET FRAME MUST BE GROUNDED. CONNECT AWG. NO. 6 WIRE OR LARGER FROM GROUND TERMINAL (GND) TO EARTH GROUND.
 - B. BATTERY NEGATIVE TERMINAL IS CONNECTED TO GROUND.
 - C. IDLING OF THE ENGINE AT SPEEDS SLOWER THAN THOSE ATTAINABLE THROUGH THE CONTROLS MAY RESULT IN DAMAGE TO ELECTRICAL COMPONENTS.

1. PRESTART CHECKS

- A. CHECK RADIATOR COOLANT, ENGINE LUBE OIL, FUEL, AND BATTERY ELECTROLYTE LEVEL.
- B. CHECK FUEL-WATER SEPARATOR, DRAIN WATER IF PRESENT.
- C. PLACE CONTROL SWITCHES TO OFF OR EQUIVALENT POSITION.
- D. PLACE FREQUENCY SELECTOR SWITCH LOCATED WITHIN THE CONTROL BOX IN DESIRED POSITION (50 HZ OR 60 HZ).

2. NORMAL START (TEMPERATURE ABOVE -25° F)

- A. CRANK THE ENGINE BY PLACING THE MASTER SWITCH IN THE START POSITION. DO NOT CRANK FOR CONTINUOUS PERIODS LONGER THAN 15 SECONDS.

- B. AT TEMPERATURES BELOW APPROXIMATELY 40° F IT MAY BE NECESSARY TO USE THE ETHER PRIMER. WHILE CRANKING THE ENGINE (HOLD MASTER SWITCH IN START POSITION), PUSH THE ETHER PRIMER SWITCH AS REQUIRED TO ACCELERATE THE ENGINE TO GOVERNED SPEED.
- C. HOLD MASTER SWITCH IN START POSITION UNTIL OIL PRESSURE BUILDS UP TO AT LEAST 25 PSI THEN RELEASE TO PRIME & RUN POSITION.
- D. ADJUST VOLTAGE AND FREQUENCY TO PROPER VALUES. IF NECESSARY, RESET FAULT INDICATOR LIGHTS.
- E. UNDER NORMAL CONDITIONS RUN ENGINE AT NO LOAD FOR 5 MINUTES FOR WARM UP. IF REQUIRED, LOAD CAN BE APPLIED IMMEDIATELY.
- F. CLOSE THE AC CIRCUIT INTERRUPTER BY PLACING THE AC CIRCUIT INTERRUPTER SWITCH IN THE CLOSED POSITION.

3. STOPPING THE SET

- A. REMOVE LOAD BY PLACING THE AC CIRCUIT INTERRUPTER SWITCH IN OPEN POSITION.
- B. ALLOW ENGINE TO OPERATE FOR APPROXIMATELY 5 MINUTES AT NO LOAD.
- C. STOP UNIT BY PLACING MASTER SWITCH IN OFF POSITION.

INSTRUCTIONS

4. PARALLEL OPERATION (2 OR MORE LIKE SETS)

- A. MAKE CONNECTIONS BETWEEN SETS AND LOAD AS DESCRIBED IN THE OPERATING MANUAL.
- B. CONNECT PARALLELING CABLE.
- C. START UNITS NO. 1 AND NO. 2 PER STARTING INSTRUCTIONS.
- D. ADJUST VOLTAGE AND FREQUENCY TO DESIRED VALUE (MUST BE SAME ON BOTH UNITS).
- E. CLOSE AC CIRCUIT INTERRUPTER ON UNIT NO. 1 ONLY.
- F. PLACE UNIT-PARALLEL SWITCH ON BOTH SETS IN PARALLEL POSITION.
- G. OBSERVE SYNCHRONIZING LIGHTS ON UNIT NO. 2 WHICH SHOULD BE ALTERNATELY GLOWING DARK AND BRIGHT IN UNISON. ADJUST FREQUENCY OF UNIT NO. 2 SLIGHTLY AS NECESSARY TO CAUSE LIGHTS TO SLOWLY GLOW BRIGHT AND DARK IN UNISON.
- H. WHEN BOTH LAMPS ARE DARK, CLOSE THE AC CIRCUIT INTERRUPTER ON UNIT NO. 2. (THE UNITS ARE NOW OPERATING IN PARALLEL AND SHOULD APPROXIMATELY DIVIDE KILOWATT LOAD AND CURRENT EQUALLY.)
- 5. REFER TO APPLICABLE TECHNICAL MANUAL FOR ADDITIONAL INFORMATION ON MAINTENANCE AND TROUBLESHOOTING PROCEDURES.

SERVICE INSTRUCTIONS

FUEL AND OIL			COOLANT	
AMBIENT TEMPERATURE	DIESEL FUEL	LUBRICATING OIL	AMBIENT TEMPERATURE	RADIATOR COOLANT
+20° F TO +120° F	VV-F-800 GR DF-2	MIL-L-2104C OE HDO-30	+40° F TO +120° F	WATER MIL-A-53009
0° F TO +20° F	VV-F-800 GR DF-1	MIL-L-2104C OE HDO-10	-25° F TO +120° F	WATER MIL-A-46153
-25° F TO 0° F	VV-F-800 GR DF-1	MIL-L-46167	-25° F TO +120° F	MIL-A-11755
-25° F TO 0° F	VV-F-800 GR DF-A	MIL-L-46167		

SYSTEM CAPACITY

FUEL TANK	LUBRICATING OIL		COOLING SYSTEM	
	CRANKCASE	FILTERS	RADIATOR AND OVERFLOW	BLOCK
43 GALLONS	FULL 18 QTS.	LOW 17 QTS.	FILTERS DRAIN TO CRANKCASE -0- QTS.	9.5 QTS. 11 QTS.

NOTE: FOR OPERATION USING JP4, JP5, OR JP8 FUEL REFER TO APPLICABLE OPERATING INSTRUCTION MANUAL.

30554-88-21671

FIGURE 2-8. Operating Instruction Plate

US DEPARTMENT OF DEFENSE
 NATO STANDARD OTAN

GENERATOR SET DIESEL ENGINE 60KW 50/60HZ

MODEL MEP-806A NSN 6115-01-274-7390

SER NO RZJ REG NO. []

TM 9-6115-645-10 NAVFAC 9-6115-645-10
 TO 35C2-3-444-11 TM 09244A/09245A-10/1

VOLTS 120/208V 3PH,
 208/416V 3PH

AMPS 208, 104 PF 0.8

DRY WT 3556 LB LG 87 IN W 35.7 IN HGT 59 IN

DATE MFD [] CONTR NO DAAK01-88-D-0082

WARRANTY [] DATE INSP []

MFD BY LIBBY CORP INSP STAMP []

30554-88-20063-09

US DEPARTMENT OF DEFENSE
 NATO STANDARD OTAN

GENERATOR SET DIESEL ENGINE 60KW 400HZ

MODEL MEP-816A NSN 6115-01-274-7395

SER NO RZJ REG NO. []

TM 9-6115-645-10 NAVFAC 9-6115-645-10
 TO 35C2-3-444-11 TM 09244A/09245A-10/1

VOLTS 120/208V 3PH,
 208/416V 3PH

AMPS 208, 104 PF 0.8

DRY WT 3606 LB LG 87 IN W 35.7 IN HGT 59 IN

DATE MFD [] CONTR NO DAAK01-88-D-0082

WARRANTY [] DATE INSP []

MFD BY LIBBY CORP INSP STAMP []

30554-88-20063-10

US DEPARTMENT OF DEFENSE
 NATO STANDARD OTAN

GENERATOR SET DIESEL ENGINE 60KW 50/60HZ

MODEL MEP-806A NSN 6115-01-274-7390

SER NO FZ REG NO. []

TM 9-6115-645-10 NAVFAC 9-6115-645-10
 TO 35C2-3-444-11 TM 09244A/09245A-10/1

VOLTS 120/208V 3PH,
 208/416V 3PH

AMPS 208, 104 PF 0.8

DRY WT 3556 LB LG 87 IN W 35.7 IN HGT 59 IN

DATE MFD [] CONTR NO DAAK01-94-D-0036

WARRANTY [] DATE INSP []

MFD BY FERMONT DIV INSP STAMP []

30554-88-20063-09

US DEPARTMENT OF DEFENSE
 NATO STANDARD OTAN

GENERATOR SET DIESEL ENGINE 60KW 400HZ

MODEL MEP-816A NSN 6115-01-274-7395

SER NO FZ REG NO. []

TM 9-6115-645-10 NAVFAC 9-6115-645-10
 TO 35C2-3-444-11 TM 09244A/09245A-10/1

VOLTS 120/208V 3PH,
 208/416V 3PH

AMPS 208, 104 PF 0.8

DRY WT 3606 LB LG 87 IN W 35.7 IN HGT 59 IN

DATE MFD [] CONTR NO DAAK01-94-D-0036

WARRANTY [] DATE INSP []

MFD BY FERMONT DIV INSP STAMP []

30554-88-20063-10

Figure 2-9. Identification Plates

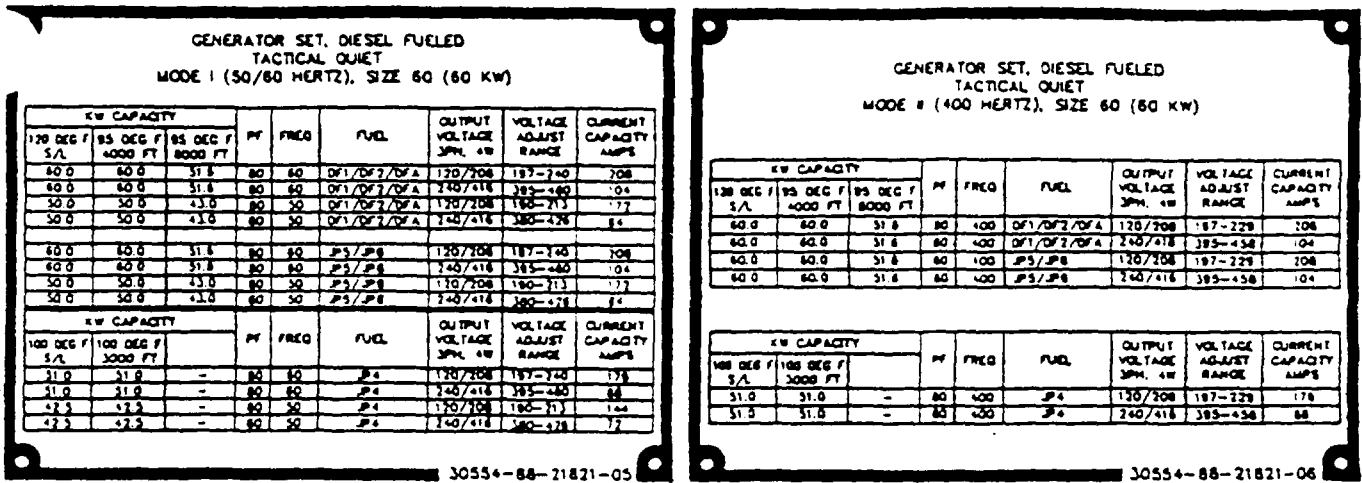

Figure 2-10. Set Rating Identification Plate

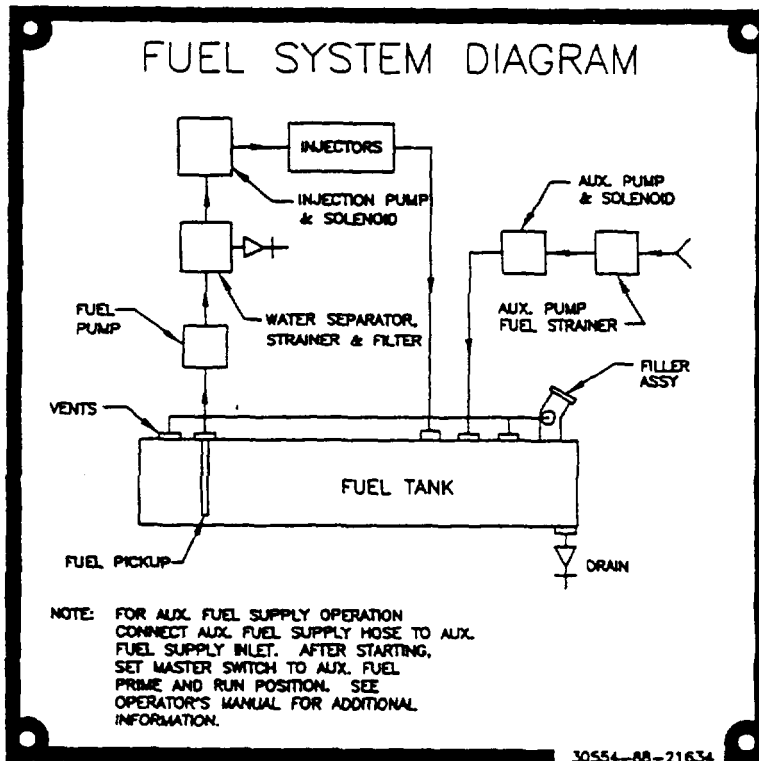

Figure 2-10.1. Fuel System Diagram Plate

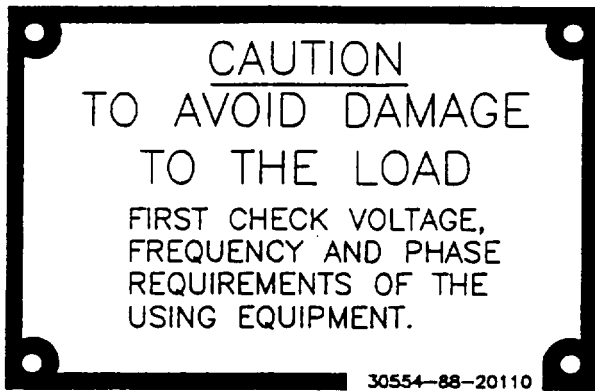

FIGURE 2-11. Voltage Connection
Caution Plate

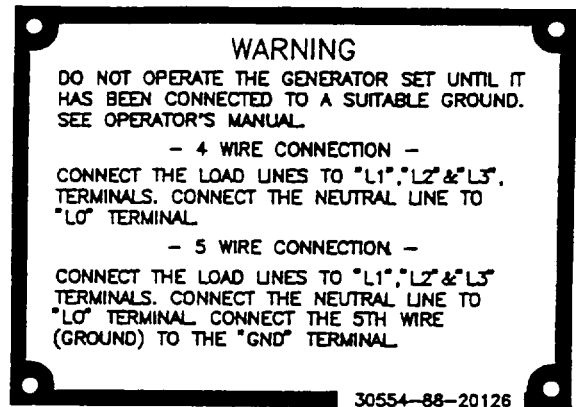

FIGURE 2-12. Grounding Stud
Plate

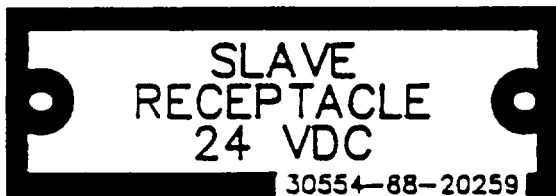

FIGURE 2-13. NATO Slave Receptacle
Plate



FIGURE 2-14. Paralleling
Receptacle Plate

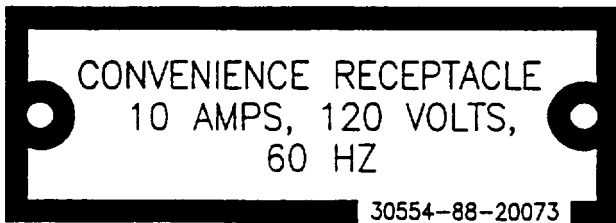

FIGURE 2-15. Convenience
Receptacle Plate

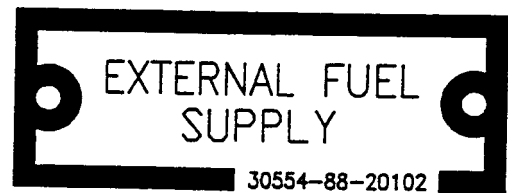

FIGURE 2-16. External Fuel
Supply Plate

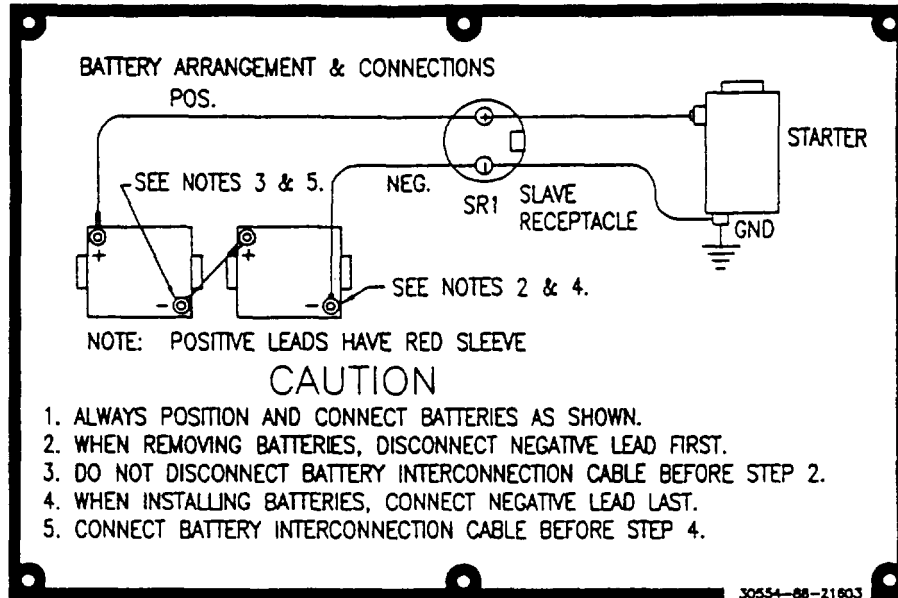

Figure 2-17. Battery Connection Instruction Plate

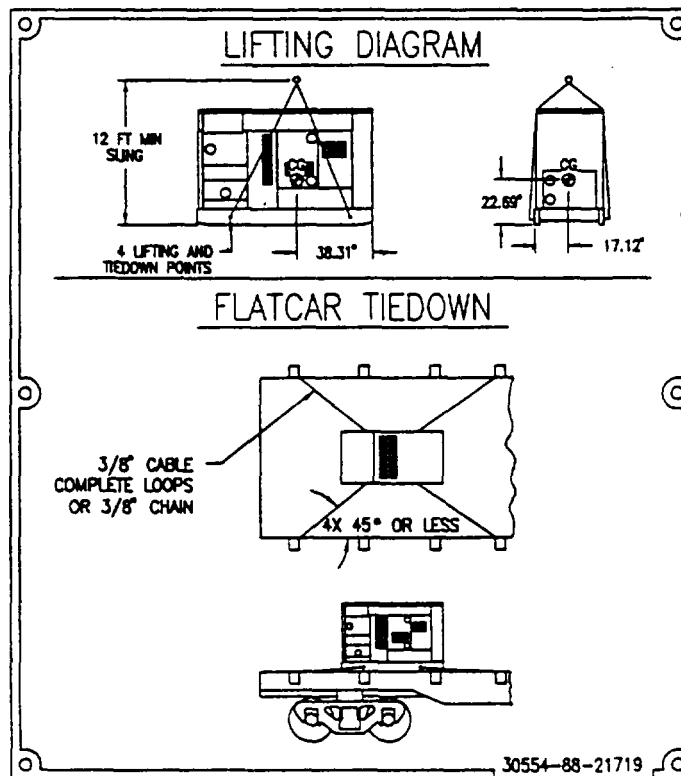

Figure 2-18. Lifting and Tiedown Diagram Plate

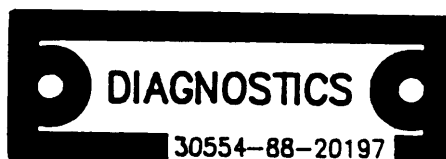

FIGURE 2-19. Diagnostics Plate

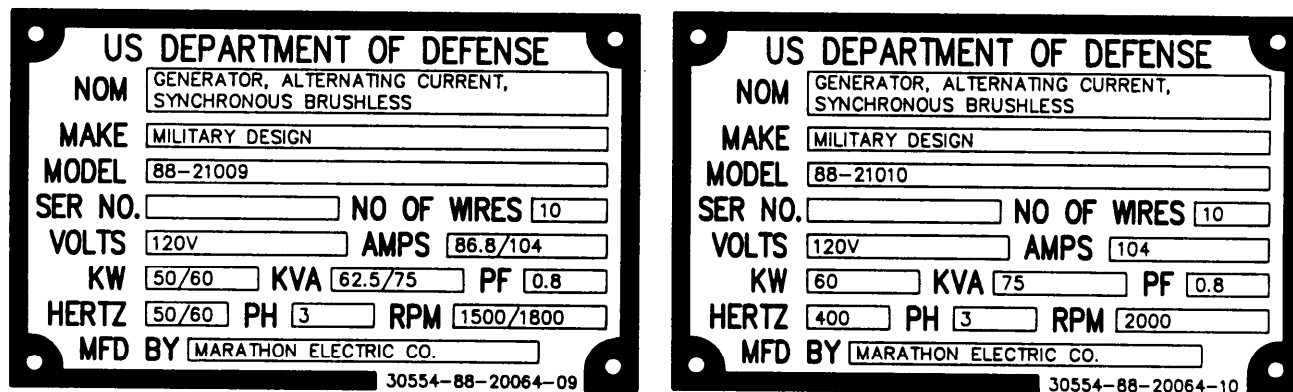

FIGURE 2-20. Generator Identification Plate

SECTION IV. OPERATION UNDER UNUSUAL CONDITIONS

2-13 OPERATION IN EXTREME COLD
WEATHER BELOW -25°F
(-31°C) .

The generator set operates in ambient temperatures as low as -25°F (-31°C) without special winterization equipment. To ensure satisfactory operation under extreme cold weather the following steps must be taken:

WARNING

Avoid contacting metal items with bare skin in extreme cold weather. Failure to observe this warning can cause personal injury.

- a. Keep generator set and surrounding area as free of ice and snow as practical.
- b. Keep fuel tank full to protect against moisture, condensation and accumulation of water.
- c. Ensure that proper grade diesel fuel is used.
- d. Keep batteries free from corrosion and in a well charged condition.

2-14 OPERATION IN EXTREME HEAT
ABOVE 120°F (48.8°C) .

- a. Check vents and radiator air passages frequently for obstructions.
- b. Check coolant temperature indicator frequently for any indication of overheating.
- c. Allow sufficient space for fuel expansion when filling fuel tank.
- d. Keep generator clean and free of dirt. Clean obstructions from generator intake and outlet screens.
- e. Clean external surface of engine when generator set is not operating.

2-15 OPERATION IN DUSTY OR
SANDY AREAS .

- a. If possible, provide a shelter for generator set. Use available natural barriers to shield generator set from blowing dust or sand.
- b. Wet down dusty and sandy surface areas around generator set frequently if water is available.

- c. Keep all access doors closed, as much as possible, to prevent entry of dust and sand into housing assembly.
- d. Wipe dust and sand frequently from the generator set external surface and components. Wash exterior surfaces frequently with clean water when generator set is not operating.
- e. Semite engine air cleaner assembly frequently to compensate for intake of additional dust or sand.
- f. Drain sediment frequently from fuel filter/water separator. When servicing fuel tank be careful to prevent dust or sand from entering fuel tank.
- g. Change engine oil and oil filter frequently.
- h. Store oil and fuel in dust-free containers.
- i. Ensure that generator set ground connections are free of dust and sand and connections are tight before starting the unit.

2-16 OPERATION UNDER RAINY OR HUMID CONDITIONS .

CAUTION

Failure to remove waterproof material before operating generator set could result in equipment damage.

- a. If possible, provide a shelter for generator set. Cover generator set with canvas or other waterproof material when it is not being operated.
- b. Provide adequate drainage to prevent water from accumulating on operation site.
- c. Keep all generator set access doors closed, as much as possible, to prevent entry of water into housing assembly.
- d. Drain water frequently from fuel filter/water separator.

WARNING

DC voltages are present at generator set electrical components even with generator set shut-down . Avoid grounding yourself when touching electrical components. Failure to follow this warning can result in personal injury.

- e. Remove moisture from generator set components before and after each operating period.
- f. Keep fuel tank full to protect against moisture, condensation and accumulation of water.

2-17 OPERATION IN SALT WATER AREAS .

CAUTION

Failure to remove waterproof material before operating generator set could result in equipment damage.

- a. If possible, provide a shelter for the generator set. Locate generator set so that radiator faces into prevailing winds. Use natural barriers or, if possible, construct a barrier to protect generator set from salt water. Cover generator set with canvas or other waterproof material when it is not being operated.
- b. Keep all generator access doors closed, as much as possible, to prevent entry of salt water into housing assembly.
- c. Wash exterior surfaces frequently with clean water when generator set is not operating.

- d. Check wiring connections for corrosion and wire insulation for signs of deterioration

2-18 OPERATION AT HIGH ALTITUDES .

The generator set will operate at elevations up to 4000 feet (1219.1 meters) above sea level without special adjustment or reduction in load. At elevations greater than 4000 feet (1219.1 meters) above sea level, the kilowatt rating is reduced approximately 3.5 percent for each additional 1000 feet (304.8 meters)

2-19 NATO SLAVE RECEPTACLE START OPERATION.

2-19.1 General . The NATO slave receptacle can be used to start the generator set when batteries are discharged.

2-19.2 NATO Slave Emergency Starting Procedure .

- a. Connect one end of NATO slave cable to fully charged 24 VDC system and other end to discharged generator set's NATO SLAVE RECEPTACLE.
- b. Start discharged generator set, refer to paragraph 2-9.1.
- c. Remove NATO slave cable after generator set starts.

2-20 EMERGENCY STOPPING.

Depressing the EMERGENCY STOP pushbutton will stop the generator set.

NOTE

The generator set cannot be restarted without resetting the EMERGENCY STOP pushbutton and turning MASTER SWITCH to OFF position.

2-21 OPERATION USING BATTLE, SHORT SWITCH.

CAUTION

Continued operation using the BATTLE SHORT switch can result in damage to the generator set.

NOTE

If any emergency situation requires continued operation of the generator set, the BATTLE SHORT switch is used to override all protection devices except the overspeed, short circuit devices, and EMERGENCY STOP function.

NOTE

BATTLE SHORT switch must be OFF to start generator set.

- a. Start generator set, if set is not running.

Refer to paragraph 2-9. .

- b. Lift cover on BATTLE SHORT switch and position switch to ON.

CAUTION

If the OVERSPEED light on the malfunction indicator panel is illuminated, position the AC circuit interrupter to the OPEN position until indicator goes out on each set.

2-40 Change 2

2-22 OPERATION WHILE CONTAMINATED.

The generator set will operate in a normal manner when exposed to nuclear, biological or chemical (NBC) contamination. It is capable of being operated by personnel wearing NBC clothing without special tools or support equipment. Refer to FM 3-3, FM 3-4, and FM 3-5.

2-23 USE OF THE CONVENIENCE RECEPTACLE.

WARNING

Power is available when the main contractor is open. Avoid accidental contact. Failure to observe this warning can result in severe personal injury or death by electrocution.

CAUTION

The maximum power rating for the convenience receptacle is 10 Amps. Continuous operation above 10 Amps can result in damage to the generator set.

- a. Start the generator set if it is not operating. Refer to paragraph 2-9.
- b. Ensure the load does not exceed the maximum rating.
- c. Reset the Ground Fault Circuit Interrupter.
- d. Plug appropriate connector into convenience receptacle.

CHAPTER 3

MAINTENANCE INSTRUCTIONS

SECTION I. LUBRICATION INSTRUCTIONS

3-1 LUBRICATION ORDER .

Refer to LO 9-6115-645-12
for lubrication information.

SECTION II. TROUBLESHOOTING

3-2 GENERAL .

This section lists common malfunctions you may find during operation of the generator set. You should perform the tests/inspections and corrective actions in the order listed.

This manual cannot list all malfunctions that may occur, nor all tests or inspections and corrective actions. If a malfunction is not listed or is not corrected by listed corrective actions, notify your supervisor.

NOTE

Air Force and Marine Corps users may perform maintenance only as authorized.



SYMPTOM INDEX

	Troubleshooting Procedure Page
COOLING SYSTEM	
COOLANT TEMPERATURE indicator indicates engine overheating	3-7
ELECTRICAL SYSTEM	
BATTERY CHARGE ammeter	
Shows low or no charge	3-8
Shows excessive charge	3-8
AC VOLTMETER (VOLTS AC)	
Indicates low voltage	3-8
Indicates correct voltage but Frequency meter (HERTZ) is off scale	3-9
Voltage fluctuates	3-9
Frequency meter (HERTZ)	
Frequency fluctuates	3-9
AC CIRCUIT INTERRUPTER	
Light fails to light when AC CIRCUIT INTERRUPTER switch is closed	3-9
Light fails to come on generator Set No. 2 in parallel operation	3-10
SYNCHRONIZING LIGHTS	
Fail to light	3-10
Do not glow bright and dark in unison on generator Set No. 2 during parallel operation	3-10
ENGINE	
Fails to crank	3-4
Cranks but fails to start	3-4
Stops when MASTER SWITCH is released from START position	3-4
Stops suddenly	3-5
Runs erratically or misfires	3-5
Does not develop full power	3-5
Knocks	3-6

SYMPTOM INDEX - Continued

EXHAUST SYSTEM	
Blue or white exhaust smoke	3-6
Black exhaust smoke	3-6
LUBRICATING SYSTEM	
Low oil pressure	3-6

Table 3-1. Troubleshooting

MALFUNCTION

TEST OR INSPECTION

CORRECTIVE ACTION

1. **Engine fails to crank.**

Step 1. Check that DEAD CRANK switch is in the NORMAL position.
Place switch in NORMAL position.

Step 2. Check that DC CONTROL POWER circuit breaker is energized (in).
If DC CONTROL POWER circuit breaker is deenergized (out), go to Step 4.

Step 3. Check that EMERGENCY STOP switch is out.

Step 4. Defect in Engine Starting/Electrical System. Check battery connections.
If loose or corroded, notify next higher maintenance level.

2. **Engine cranks but fails to start.**

Step 1. Cold ambient temperature.
If ambient temperature is below 40°F (4°C) turn MASTER SWITCH to START and position
ETHER switch to ON, refer to paragraph 2-9.1.

Step 2. Check for dirty air cleaner element.
Service air cleaner assembly, refer to paragraph 3-3.3.2.

Step 3. Check for dirty fuel filter/water separator.
Service fuel filter/water separator, refer to paragraph 3-3.6.2. If engine still fails to start, notify
next higher maintenance level.

3. **Engine starts but stops when MASTER SWITCH is released from START position.**

Step 1. Check for proper starting procedure.
Hold MASTER SWITCH in START position until 25 psi (172 kpa) is reached, refer to paragraph
2-9.1.

Step 2. Check to see if any FAULT INDICATOR lights are lit.
NO FUEL light is lit, refer to paragraph 3-3.4.2. If any other lights are lit, notify next higher
maintenance level.

TABLE 3-1. Troubleshooting - Continued

MALFUNCTION	TEST OR INSPECTION	CORRECTIVE ACTION
-------------	--------------------	-------------------

4. Engine stops suddenly.

Step 1. Check to see if any FAULT INDICATOR lights are lit.
NO FUEL light is lit, refer to paragraph 3-3.4.2.
If any other lights are lit, go to step 2.

Step 2. Check that DC CONTROL POWER circuit breaker is energized (in).
If DC CONTROL POWER circuit breaker is deenergized (out), notify next higher maintenance level.

5. Engine runs erratically or misfires.

Step 1. Check for dirty air cleaner element.
Service air cleaner assembly, refer to paragraph 3-3.3.2.

Step 2. Check for contaminated fuel.
Service fuel filter/water separator, refer to paragraph 3-3.6.2.

Step 3. Check for improper type of fuel.
If improper fuel is suspected, refer to TABLE 3-2, notify next higher maintenance level.

6. Engine does not develop full power.

Step 1. Check for dirty air cleaner element.
Service air cleaner assembly, refer to paragraph 3-3.3.2.

Step 2. Check for contaminated fuel.
Service fuel filter/water separator, refer to paragraph 3-3.6.2.

Step 3. Check for restricted exhaust system.
Make sure exhaust opening is free from obstructions. If no obstructions are found, notify next higher maintenance level.

Step 4. Check for improper type of fuel.
If improper type of fuel is suspected, refer to TABLE 3-2, notify next higher maintenance level.

TABLE 3-1. Troubleshooting - Continued

MALFUNCTION	TEST OR INSPECTION	CORRECTIVE ACTION
-------------	--------------------	-------------------

7. Engine knocks.

Step 1. Check for low lubrication oil level.
If necessary add oil, refer to LO 9-6115-645-12.

Step 2. Check for loose parts or foreign objects in engine compartment.
If no loose parts or foreign objects are found, go to Step 3.

Step 3. Check for improper type of fuel.
If improper type of fuel is suspected, refer to TABLE 3-2, notify next higher maintenance level.

8. Blue or white exhaust smoke.

Check for improper type of fuel.
If improper type of fuel is suspected, refer to TABLE 3-2, notify next higher maintenance level.

9. Black exhaust smoke.

Step 1. Check for improper type of fuel.
If improper type of fuel is suspected, refer to TABLE 3-2, notify next higher maintenance level.

Step 2. Check for dirty air cleaner element.
Service air cleaner assembly, refer to paragraph 3-3.2.2.

Step 3. Check for generator set overload.
Check for generator set overload by checking the ammeter (PERCENT RATED CURRENT) and the kilowattmeter (PERCENT POWER) on the control panel assembly, refer to FIGURE 2-1. If unable to adjust, notify next higher maintenance level.

10. Low oil pressure.

Step 1. Check for low lubrication oil level.
If necessary add oil, refer to LO 9-6115-645-12.

Table 3-1. Troubleshooting - Continued

MALFUNCTION	TEST OR INSPECTION	CORRECTIVE ACTION
	Step 2.	Check for high coolant temperature, above 200°F (93°C), refer to Figure 2-1. If coolant temperature is high, go to Step 3.
	Step 3.	Check coolant level. If low, add coolant, refer to paragraph 3-3.4.2. If full, go to Step 4.
	Step 4.	Check for obstruction in air intake system. If obstructions are found, remove debris. If no obstructions are found, go to Step 5.
	Step 5.	Check for loose fan belts. If loose, notify next higher maintenance level.
11.	COOLANT TEMPERATURE indicator indicates engine overheating.	
	Step 1.	Check for generator set overload. Check for generator set overload by checking the ammeter (PERCENT RATED CURRENT) and the kilowattmeter (PERCENT POWER) on the control panel assembly, refer to Figure 2-1. If unable to adjust, notify next higher maintenance level.
	Step 2.	Check coolant level. If low, add coolant, refer to paragraph 3-3.4.2. If full, go to Step 3.
	Step 3.	Check for low lubrication oil level. If necessary add oil, refer to LO 9-6115-645-12. If full, go to Step 4.
	Step 4.	Check for obstruction in air intake system. If obstructions are found, remove debris. If no obstructions are found, go to Step 5.
	Step 5.	Check for loose fan belts. If loose, notify next higher maintenance level.

Table 3-1. Troubleshooting - Continued

MALFUNCTION

TEST OR INSPECTION

CORRECTIVE ACTION

12. BATTERY CHARGE ammeter shows low or no charge.

- Step 1. Check BATTERY CHARGER FUSE.
If BATTERY CHARGER FUSE (Figure 2-1) is blown, notify next higher maintenance level.
- Step 2. Check fan belts.
If loose, notify next higher maintenance level.
- Step 3. Check for loose or broken wires. Check for loose or broken wires at the back of the battery charging alternator (Figure 1-2) and BATTERY CHARGER ammeter (Figure 2-1).
If wires are loose or broken, notify next higher maintenance level.

13. BATTERY CHARGE ammeter shows excessive charging after prolonged operation.

- Step 1. Check batteries for low electrolyte level.
If low refer to paragraph 3-3.2.2. If level is correct, go to step 2.
- Step 2. Check battery connections.
If loose or corroded, notify next higher maintenance level.

14. AC voltmeter (VOLTS AC) does not indicate correct voltage.

- Step 1. Check that AM-VM transfer switch position corresponds to readings on the AC voltmeter (VOLTS AC), refer to Table 2-4.
Set VOLTAGE adjust potentiometer.
- Step 2. Check for loose or broken wires at back of AM-VM transfer switch, VOLTAGE adjust potentiometer, and AC voltmeter (VOLTS AC).
If wires are loose or broken, notify next higher maintenance level.

TABLE 3-1. Troubleshooting - Continued

MALFUNCTION	TEST OR INSPECTION	CORRECTIVE ACTION
15. AC voltmeter (VOLTS AC) indicates correct voltage, but frequency meter (HERTZ) is off scale.		
	Step 1.	Check FREQUENCY adjust potentiometer. Set FREQUENCY adjust potentiometer.
	Step 2.	Check for loose or broken wires at back of FREQUENCY adjust potentiometer. If wires are loose or broken, notify next higher maintenance level.
16. AC voltmeter (VOLTS AC) fluctuates.		
		Check back of AC voltmeter (VOLTS AC) for loose or broken wires. If wires are loose or broken, notify next higher maintenance level.
17. Frequency meter (HERTZ) fluctuates.		
		Check back of frequency meter (HERTZ) for loose or broken wires. If wires are loose or broken, notify next higher maintenance level.
18. AC CIRCUIT INTERRUPTER light fails to light when AC CIRCUIT INTERRUPTER switch is closed.		
	Step 1.	TEST AC CIRCUIT INTERRUPTER light by depressing. If light fails to light, refer to next higher maintenance level.
	Step 2.	Check load cables for proper connection. For proper connection of the load cables, refer to paragraph 2-7.2. If correct go to Step 3.
	Step 3.	Ensure load does not exceed generator rating. Decrease load, if load is correct, refer to next higher maintenance level.

TABLE 3-1. Troubleshooting - Continued

MALFUNCTION	TEST OR INSPECTION	CORRECTIVE ACTION
19. SYNCHRONIZING LIGHTS fail to light.		
	Step 1.	Check that parallel cable is connected. Connect paralleling cable, refer to paragraph 2-10.2.
	Step 2.	Check PARALLEL UNIT switch. Place PARALLEL UNIT switch in correct position.
20. SYNCHRONIZING LIGHTS on generator set No. 2 do not glow bright and dark in unison during parallel operation.		
	Step 1.	Check that load cables are connected properly. For proper connection of load cables, refer to paragraph 2-7.2. If properly connected, go to Step 2.
	Step 2.	Ensure FREQUENCY SELECT switches are in correct positions. Frequency must be the same on both generator sets (MEP-806A).
21. AC CIRCUIT INTERRUPTER light fails to come on generator set No. 2 in parallel operation.		
	Step 1.	Test light by depressing. If light fails to light, notify next higher maintenance level. If light comes on, go to Step 2.
	Step 2.	FREQUENCY adjust potentiometer is not properly adjusted. Set FREQUENCY adjust potentiometer.
22. No voltage at the Convenience Receptacle.		
	Step 1.	Open control panel and inspect circuit breaker on side of Ground Fault Circuit Interrupter device. If tripped, reset device. Check fuse on black wire of Ground Fault Circuit Interrupter for generator sets, contract number DAAK01-88-D-D082.
	Step 2.	Check reset button for red band. If red band is visible, push reset button. If Ground Fault Circuit Interrupter can not be reset, refer to next higher maintenance level.

SECTION III. MAINTENANCE PROCEDURES

3-3 GENERATOR SET INSPECTION
AND SERVICE.

3-3.1 Introduction. This section contains operator maintenance procedures. Deficiencies noted during inspection which are beyond the maintenance scope of the operator shall be reported to next higher maintenance level.

3-3.2 Batteries.

WARNING

Battery acid can cause burns to unprotected skin.

WARNING

Batteries give off flammable gas. Do not smoke or use open flame when performing maintenance. Flames and explosion could result in personal injury or death.

3-3.2.1 Inspection.

- a. Shut down generator set, refer to paragraph 2-9.2.
- b. Open battery access door.
- c. Inspect for damaged battery case, corrosion, or damaged and loose connections on terminal cable, and damaged or missing battery caps.

WARNING

Batteries give off flammable gas. Do not smoke or use open flame when performing maintenance. Flames and explosion could result in personal injury or death.

- d. Remove battery caps.

CAUTION

Electrolyte level must cover battery plates in all cells. Failure to observe this caution can cause damage to the battery.

NOTE

Electrolyte level should be at bottom of each cap cylinder.

- e. Inspect electrolyte level.
- f. Perform service procedures if required.
- g. Install battery caps.
- h. Close battery access door.

3-3.2.2 Service.

- a. Shut down generator set, refer to paragraph 2-9.2.

- b. Open battery access door.

WARNING

Batteries give off flammable gas. Do not smoke or use open flame when performing maintenance. Flames and explosion could result in personal injury or death.

- c. Remove battery caps.

NOTE

Electrolyte level should be at bottom of each cap cylinder.

- d. Add distilled water to each battery cell as required.
- e. Replace battery caps.
- f. Close battery access door.
- g. If necessary contact next higher level of maintenance to clean or replace batteries or battery terminals.

3-3.3 Air Cleaner Assembly
(FIGURE 3-1) .

3-3.3.1 Inspection.

- a. Shut down generator set, refer to paragraph 2-9.2.
- b. Open air cleaner access door (rear of generator set).

- c. Open left side engine compartment access door.
- d. Inspect air cleaner housing (5) for dents, corrosion, missing hardware and other damage.
- e. Inspect restriction indicator (6) for indication of a clogged air cleaner element (4).
- f. Close air cleaner access door.

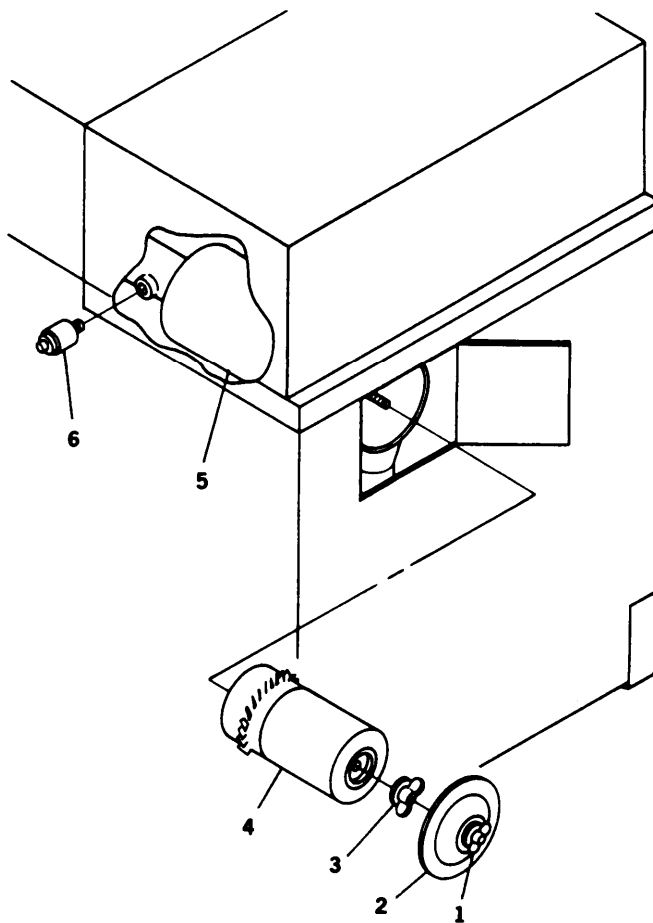

FIGURE 3-1. Air Cleaner Element Replacement

3-3.3.2 Service.

WARNING

- a. Shut down generator set, paragraph 2-9.2.
- b. Open air cleaner access door (rear of generator set).
- c. Loosen wing nut (1) and remove end cap (2) on air cleaner housing (5).
- d. Remove wing nut (3) and air cleaner element (4). If fouled, discard air cleaner element.
- e. Inspect inside of air cleaner housing (5) for debris. Wipe housing interior with clean lint-free cloth (Item 1, Appendix D).
- f. Install air cleaner element (4), wing nut (3), end cap (2) and hand tighten wing nut (1).
- g. Close air cleaner access door.

Cooling system operates at high temperatures. Personal injury or death from burns or scalding can result from contact with high pressure steam and/or liquid.

- c. Check radiator for dirt, leaves, insects, etc. blocking air flow.
- d. Check radiator and hoses for leaks, loose connections, loose mountings, corrosion, chafing, and missing parts.
- e. Check coolant level at coolant recovery (overflow) bottle.
- f. Close both engine access doors.

3-3.4.2 Service.

WARNING

3-3.4 Cooling System .

3-3.4.1 Inspection.

- a. Shut down generator set, refer to paragraph 2-9.2.
- b. Open both engine access doors.

Cooling system operates at high temperatures. Personal injury or death from burns or scalding can result from contact with high pressure steam and/or liquid.

- a. Shut down generator set, refer to paragraph 2-9.2.

TABLE 3-2. Coolant

COOLANT		
AMBIENT TEMPERATURE	RADIATOR COOLANT	RATIO
+40°F TO +120°F (+4°C TO +49°C)	Water: MIL-A-53009 INHIBITOR, CORROSION	35:1
-25°F TO +120°F (-32°C TO +49°C)	Water: MIL-A-46153 ANTIFREEZE	1:1
-25°F TO +120°F (-32°C TO +49°C)	MIL-A-11755 ANTIFREEZE	NA

- b. Open right side engine access door.
- c. Remove cap on coolant recovery (overflow) bottle.
- d. Fill coolant recovery (overflow) bottle to HOT line if coolant is hot or to COLD line if coolant is cold with proper coolant/antifreeze in accordance with TABLE 3-2.
- e. Install coolant recovery (overflow) bottle cap.
- f. Close right side engine access door.

3-3.5 Fuel Tank.

3-3.5.1 Inspection.

- a. Place MASTER SWITCH in PRIME & RUN or PRIME & RUN AUX FUEL position.
- b. Check fuel level by observing FUEL LEVEL indicator.
- c. Remove fuel cap and ensure strainer is free of dirt and other foreign material.

TABLE 3-3. Diesel Fuel

FUEL	
AMBIENT TEMPERATURE	DIESEL FUEL
+20°F TO +120°F (-7°C TO +49°C)	W-F-800 GRADE DF-2 JP4, JP5, JP8
0°F TO +20°F (-17°C TO +7°C)	W-F-800 GRADE DF-1 JP4, JP5, JP8
-25°F TO 0°F (-32°C TO -17°C)	W-F-800 GRADE DF-1
-25°F TO 0°F (-32°C TO -17°C)	W-F-800 GRADE DF-A

3-3.5.2 Service.

- c. Remove fuel strainer, clean as necessary, and reinstall.

WARNING

The fuels in this generator set are highly explosive. DO NOT smoke or use open flame when performing maintenance. Flames and explosion can occur resulting in severe personal injury or death.

CAUTION

Use only specified diesel fuel to service the fuel tank. Refer to TABLE 3-3. Otherwise, equipment damage could result.

- a. Shut down generator set, refer to paragraph 2-9.2.
- b. Remove fuel cap.

NOTE

Fuel tank holds 43 gallons (162.7 liters) .

- d. Add diesel fuel to fuel tank.
- e. Install fuel cap.

3-3.6 Fuel Filter/Water Separator (FIGURE 3-2)

3-3.6.1 Inspection.

- a. Shut down generator set, refer to paragraph 2-9.2.
- b. Open right side engine access door.

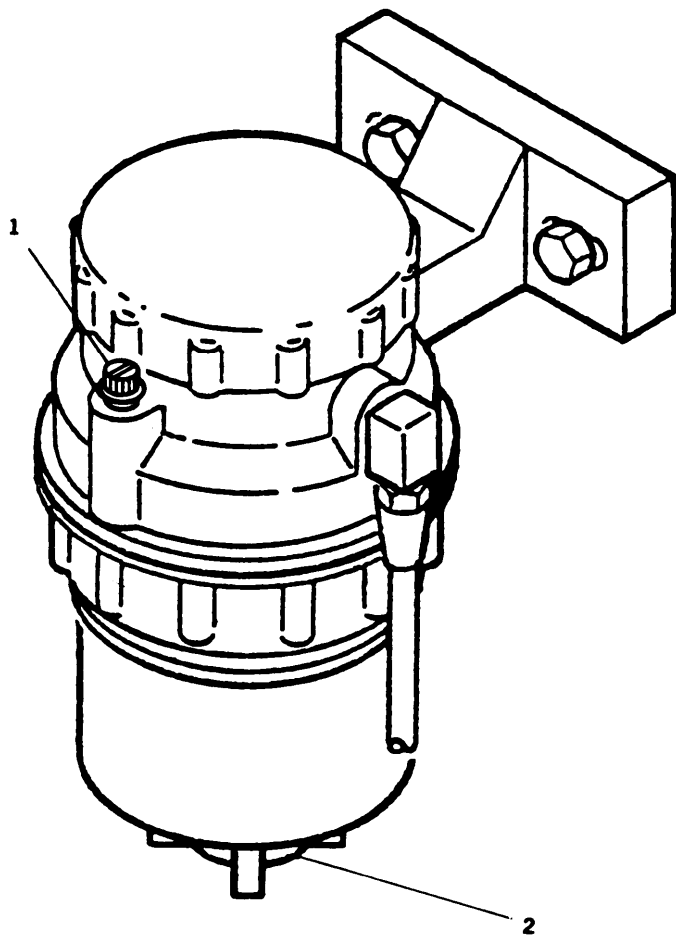

FIGURE 3-2. Draining Fuel Filter/Water Separator

- d. Close engine access door.

3-3.6.2 Service.

- a. Shut down generator set, refer to paragraph 2-9.2.
- b. Open right side engine access door.
- c. Open fuel drain cock (2) and air vent (1) on fuel filter/water separator assembly and drain any sediment and water into a suitable container.
- d. Close drain cock (2) and air vent (1).
- e. Close right side engine access door.

3-3.7 Lubrication System .

3-3.7.1 Inspection.

- a. Shut down generator set, refer to paragraph 2-9.2.
 - b. Open both engine access doors.
 - c. Inspect engine assembly for oil leaks.
 - d. Check for damage, proper mounting, or missing parts.
- c. Inspect fuel filter/water separator assembly for proper mounting, cracks, dents, leaks, loose fuel lines and other damage.

CAUTION

The dipstick is marked so that the crankcase oil can be checked while engine is stopped or running. Always make sure correct side of dipstick is checked. Remove oil filler cap when checking oil with engine running.

- e. Check engine crankcase oil level. Refer to LO 9-6115-645-12.
- f. Close both engine access doors.

3-3.7.2 Service.

- a. Shut down generator set, refer to paragraph 2-9.2.
- b. Open right engine access door.
- c. Remove oil filler cap.
- d. Add oil to engine crankcase. Refer to LO 9-6115-645-12.
- e. Install oil filler cap.
- f. Close right side engine access door.

APPENDIX A

REFERENCES

A-1 SCOPE.

This appendix lists all forms, field manuals, technical manuals and miscellaneous publications referenced in this manual .

A-2 FORMS.

Equipment Control
LogDA Form 2408-9

Quality Deficiency
ReportSF 368

Equipment Inspection and
Maintenance
WorksheetDA Form 2404

Recommended Changes to
Publications and Blank
FormsDA Form 2028

Recommended Changes to Equipment
PublicationsDA Form 2028-2

Reporting Errors and
Recommending Improvements to
Technical
Publications NAVMC 10772

A-3 FIELD MANUALS.

Electric Power Generation in the
FieldFM 20-31

First AidFM 21-11

NBC Contamination
Avoidance FM 3-3

NBC ProtectionFM 3-4
NBC DecontaminationFM 3-5

A-4 TECHNICAL MANUALS.

Marine Corps Forms. .TM 4700-15/1

A-5 MISCELLANEOUS PUBLICATIONS.

The Army Maintenance Management
System (TAMMS). . DA PAM 738-750

Air Force Maintenance Forms and
RecordsAFR 66-1

Lubrication
OrderLO 9-6115-645-12

Warranty Technical
BulletinTB 9-6115-645-24

Military Standard
AbbreviationsMIL-STD-12

Quality Deficiency
ManualMCO 4855.10

APPENDIX B

COMPONENTS OF END ITEM AND BASIC ISSUE ITEMS LISTS

SECTION I. INTRODUCTION

B-1 SCOPE.

This appendix lists components of end item and basic issue items for the generator set to help you inventory items required for safe and efficient operation.

transferred between property accounts. The illustrations will assist you with hard-to-identify items. This manual is your authority to request/requisition replacement BII, based on TOE/MTOE authorization of the end item.

B-2 GENERAL.

The Components of End Item and Basic Issue Items Lists are divided into the following sections:

a. Section II. Components of End Item (COEII). This listing is for informational purposes only, and is not authority to requisition replacements. These items are part of the end item, but are removed and separately packaged for transportation or shipment. As part of the end item, these items must be with the end item whenever it is issued or transferred between property accounts. Illustrations are furnished to assist you in identifying the items.

b. Section III. Basic Issue Items (BII). These are the minimum essential items required to place the generator set in operation, to operate it, and to perform emergency repairs. Although shipped separately packaged, BII must be with the generator set during operation and whenever it is

B-3 EXPLANATION OF COLUMNS.

The following provides an explanation of columns found in the tabular listing:

a. Column (1) - Illustration Number (Illus Number). This column indicates the number of the illustration in which the item is shown.

b. Column (2) - National Stock Number. Indicates the National Stock Number assigned to the item and will be used for requisitioning purposes.

c. Column (3) - Description. Indicates the Federal item name and, if required, a minimum description to identify and locate the item. The last line for each item indicates the Commercial and Government Entity (CAGE) code (in parentheses) followed by the part number. Usable on code identifies the specific type of generator set (50/60 Or 400 Hz) to which the BII applies. However, there are no BII which are specific to either the 50/60 or 400 Hz generator sets.

APPENDIX B

d. Column (4) - Unit of Measure (U/M). Indicates the measure used in performing the actual operational/maintenance function. This measure is expressed by a two-character alphabetical abbreviation (e.g., ea, in, pr).

e. Column (5) - Quantity required (Qty reqd). Indicates the quantity of the item authorized to be used with/on the equipment.

SECTION II. COMPONENTS OF END ITEM LIST

NONE

SECTION III. BASIC ISSUE ITEMS

(1) Illus Number	(2) National Stock Number	(3) Description Cage and Part Number	Usable On Code	(4) U/M	(5) Qty reqd
1		TECHNICAL MANUAL, TM 9-6115-645-10		EA	1
2		LUBRICATION ORDER, LO 9-6115-645-12		EA	1
3		WARRANTY TECHNICAL BULLETIN TB 9-6115-645-24		EA	1

APPENDIX B

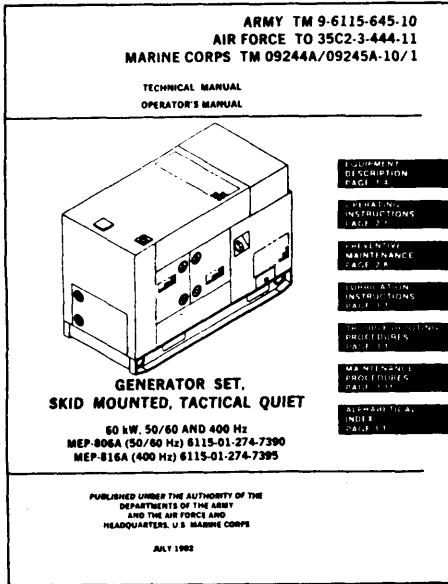

1. Technical Manual

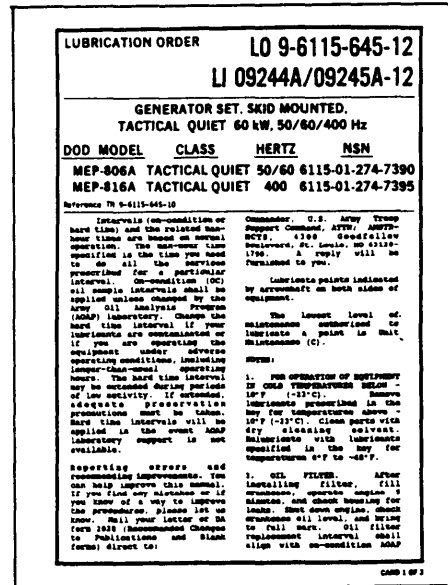

2. Lubrication Order

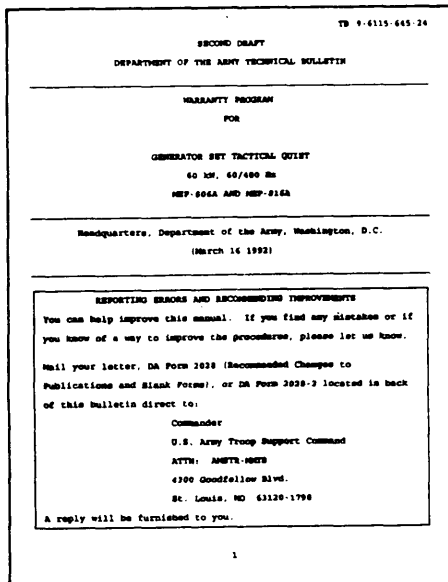

3. Warranty Technical Bulletin

APPENDIX C
 ADDITIONAL AUTHORIZATION LIST

SECTION I. INTRODUCTION

C-1 SCOPE.

This appendix lists additional items you are authorized for the support of the generator set.

C-2 GENERAL.

This list identifies items that do not have to accompany the generator set and that do not have to be turned in with it. These items are all authorized to you by CTA, MTOE, TDA, or JTA.

C-3 EXPLANATION OF LISTING.

National stock numbers, descriptions, and quantities are provided to help you identify and request the additional items you require to support this equipment. The items are listed in alphabetical sequence by item name under the type document (i.e., CTA, MTOE, TDA, or JTA) which authorizes the item(s) to you .

SECTION II. ADDITIONAL AUTHORIZATION LIST

(1) NATIONAL STOCK NUMBER	(2) DESCRIPTION CAGE & PART NUMBER USABLE ON CODE	(3) U/M	(4) QTY AUTH
TBD	FIRE EXTINGUISHER	EA	1
TBD	FUEL ADAPTER	EA	1
TBD	FUEL CAN	EA	1
TBD	FLEXIBLE SPOUT	EA	1
TBD	HAMMER, SLIDE	EA	1

APPENDIX D

EXPENDABLE/DURABLE SUPPLIES AND MATERIALS LIST

SECTION I. INTRODUCTION

D-1 SCOPE.

This appendix lists expendable/durable supplies and materials you will need to operate and maintain the generator set. This listing is for informational purposes only and is not authority to requisition the listed items. These items are authorized to you by CTA 50-970, Expendable/Durable Items (except Medical, Class V, Repair Parts, and Heraldic Items), or CTA 8-100, Army Medical Department Expendable/Durable Items.

D-2 EXPLANATION OF COLUMNS.

a. Column (1) - Item Number. This number is assigned to the entry in the listing and is referenced in the narrative instructions to identify the material (e.g., "Use cleaning compound, item 5. Appx. D").

b. Column (2) - Level. This column identifies the lowest level of maintenance that requires the listed item.

c. Column (3) - National Stock Number. This is the National Stock Number assigned to the item; use it to request or requisition the item.

d. Column (4) - Description. Indicates the Federal item name and, if required, a description to identify the item. The last line for each item indicates the Commercial and Government Entity (CAGE) code in parentheses () followed by the part number.

Column (5) - Unit of Measure (U/M). Indicates the measure used in performing the actual maintenance function. This measure is expressed by a two-character alphabetical abbreviation (e.g., ea, in, pr). If the unit of measure differs from the unit of issue, requisition the lowest unit of issue that will satisfy your requirements.

ARMY TM 9-6115-645-10
 AIR FORCE TO 35C2-3-444-11
 MARINE CORPS TM 09244A/09245A-10/1

APPENDIX D

(1) ITEM NUMBER	(2) LEVEL	(3) NATIONAL STOCK NUMBER	(4) DESCRIPTION	(5) U/M
1	C	7920-01-338-3329	CLOTH, CLEANING	EA
2	C	6850-00-181-7929	ANTIFREEZE (81349) MIL-A-46153	GL
3	C	6810-00-107-1510	WATER, DISTILLED	GL
4	C	9150-00-189-6727	LUBRICATING OIL, ENG (81349) MIL-L-2104, OEA HDO 10	QT
5	C	9150-01-152-4117	LUBRICATING OIL, ENG (81349) MIL-L-2104, OEA HDO 15/40	QT

INDEX

Subject	Page
A	
Abbreviations, List of	1-3
AC Generator, Location of	1-6
Additional Authorization List	C-1
After You Operate PMCS	2-8
Air Cleaner Assembly, Inspection and Servicing of	3-12
Air Cleaner Assembly, Location of	1-6
Air Cleaner Element, Replacement of	3-13
Air Intake and Exhaust System, Description of	1-15
Alternator, Location of	1-4
Assembly and Preparation for Use	2-17
B	
Batteries, Inspection and Servicing of	3-11
Batteries, Location of	1-4
Battle Short Switch, Use of	2-40
Before You Operate PMCS	2-8
C	
Components of End Item and Basic Issue Items	B-1
Control Panel, Description of	2-1
Control Panel Assembly, Location of	1-6
Controls and Indicators	2-3
Convenience Receptacle, Location of	1-7
Coolant Specifications	3-14
Cooling System, Inspection and Servicing of	3-13
D	
Daily Checks	2-21
Dead Crank Switch, Location of	1-7
Dipstick, Location of	1-6
Description and Use of Operator's Controls and Indicators	2-1
Diesel Fuel Specifications	3-15
Differences Between Models	1-7
E	
Emergency Stopping	2-40
Engine, Location Of.	1-4
Engine, Servicing Lube Oil	3-17

INDEX (CONTINUED)

Subject	Page
E (CONTINUED)	
Engine Cooling System, Description of	1-14
Engine Lubrication System, Description of	1-15
Engine Starting System, Description of	1-12
Equipment Characteristics, Capabilities and Features	1-4
Equipment Data	1-7
Equipment Description	1-4
Equipment is Not Ready/Available If	2-9
Expendable/Durable Supplies and Materials List	D-1
F	
Fan Belts, Location of	1-7
Fuel Filter/Water Separator, Location of	1-6
Fuel Filter/Water Separator, Servicing of	3-16
Fuel Specifications	3-15
Fuel System, Description of	1-13
Fuel Tank, Location of	1-6
Fuel Tank, Servicing	3-15
G	
General Information	1-1
Generator Set Inspection and Service	3-11
Grounding Rod, Installation of	2-17
H , I , J	
How to Use This Manual	v
If Your Equipment Fails to Operate	2-8
Initial Adjustments	2-21
Installation of Grounding Rod	2-17
Installation of Load Cables	2-17
K , L	
Leading Particulars	1-7
Leakage Definitions for Operators PMCS	2-8
List of Abbreviations	1-3
Load Cables, Installation of	2-17
Load Output Terminal Board	1-6
Location and Description of Major Components	1-4
Lubrication Instructions	3-1
Lubrication System, Description of	1-15
Lubrication System, Inspection and Servicing of	3-16

INDEX (CONTINUED)

Subject	Page
M, N	
Maintenance Forms and Records	1-1
Maintenance Procedures	3-11
Malfunction Indicator Panel, Location of	1-6
Malfunction Indicator Panel, Description of	2-6
Model Numbers and Equipment Names	1-1
Muffler, Location of	1-4
 O	
Oil, Engine, Checking and Adding	3-16
Oil Filter, Location of	1-7
Operating Instructions	2-1
Operating Instructions on Plates	2-29
Operating Procedures	2-21
Operation at High Altitudes	2-39
Operation in Dusty or Sandy Areas	2-37
Operation in Extreme Cold Weather (-25°F [-31°C])	2-37
Operation in Extreme Heat Above 120°F (48.8°C)	2-37
Operation in Salt Water Areas	2-39
Operation Under Rainy or Humid Conditions	2-38
Operation Under Unusual Conditions	2-37
Operation Under Usual Conditions	2-17
Operation Using Battle Short Switch	2-40
Operation While Contaminated	2-40
Output Supply System, Description of	1-16
 P, Q	
Parallel Unit Operation (Load Sharing)	2-24
Paralleling Receptacle, Location of	1-7
PMCS Procedures	2-8
PMCS Table	2-10
Preparation for Movement	2-29
Preventive Maintenance Checks and Services (PMCS)	2-8
Purpose of Equipment	1-1
 R	
Radiator, Location of	1-4
References	A-1
Removal from Parallel Operation	2-28
Reporting and Correcting Deficiencies	2-9
Reporting Equipment Improvement Recommendations (EIR)	1-1

INDEX (CONTINUED)

Subject	Page
S	
Scope of Technical Manual	1-1
Self Test.	2-21
Servicing.	3-11
Skid Base, Location of	1-6
Slave Receptacle, Location of:	1-6
Slave Starting Procedures	2-39
Starter, Location of	1-4
Starting Procedure	2-22
Stopping Procedure	2-24
Symptom Index, Troubleshooting	3-2
T	
Technical Principles of Operation	1-12
Troubleshooting	3-1
Type of Manual	1-1
U, V, W	
Voltage Reconnection Terminal Board, Location of	1-6
Warranty Information	1-3
Water Pump, Location of	1-7
While You Operate PMCS	2-8

X, Y, Z

By Order of the Secretaries of the Army, Air Force, and Navy (Including the Marine Corps):

Official:

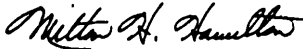
MILTON H. HAMILTON
*Administrative Assistant to the
Secretary of the Army*
05066

GORDON R. SULLIVAN
*General, United States Army
Chief of Staff*

MERRILL A. McPEAK
*General, USAF
Chief of Staff*

Official:

RONALD W. YATES
*General, USAF
Commander, Air Force Materiel Command*

DAVID E. BOTTORFF
*Rear Admiral, CEC, US Navy
Commander
Navy Facilities Engineering
Command*

RONALD D. ELLIOTT
*Executive Director
Marine Corps Systems Command*

DISTRIBUTION:

To be distributed in accordance with DA Form 12-25-E, block no. 5269, requirements for TM 9-61 15-645-10.

RECOMMENDED CHANGES TO EQUIPMENT TECHNICAL PUBLICATIONS



THEN... JOT DOWN THE DOPE ABOUT IT ON THIS FORM. CAREFULLY TEAR IT OUT, FOLD IT AND DROP IT IN THE MAIL!

SOMETHING WRONG WITH THIS PUBLICATION?

FROM: (PRINT YOUR UNIT'S COMPLETE ADDRESS)
PFC JOHN DOE
COA, 3d ENGINEER BN
FT. LEONARDWOOD, MD 63108
 DATE SENT

PUBLICATION NUMBER
 TM 9-6115-645-10

PUBLICATION DATE
 30 July 1993

PUBLICATION TITLE
 GENERATOR SET, SKID MOUNTED

BE EXACT PIN-POINT WHERE IT IS				IN THIS SPACE TELL WHAT IS WRONG AND WHAT SHOULD BE DONE ABOUT IT:
PAGE NO	PARA-GRAPH	FIGURE NO	TABLE NO	
6	2-1 a			In line 6 of paragraph 2-1a the manual states the engine has <u>6</u> cylinders. The engine on my set only has <u>4</u> cylinders. Change the manual to show <u>4</u> cylinders.
B1		4-3		Callout 16 on figure 4-3 is pointing at a <u>bolt</u> . In key to figure 4-3, item 16 is called a <u>shim</u> - Please correct one or the other.
125	line 20			I ordered a gasket, item 19 on figure B-16 by NSN 2 910-05-762-3001. I got a gasket but it doesn't fit. Supply says I got what I ordered, so the NSN is wrong. Please give me a <u>good NSN</u>

PRINTED NAME, GRADE OR TITLE, AND TELEPHONE NUMBER
JOHN DOE, PFC (268) 317-7111

SIGN HERE **JOHN DOE**
JOHN DOE

TEAR ALONG PERFORATED LINE

FILL IN YOUR
UNITS ADDRESS



FOLD BACK

DEPARTMENT OF THE ARMY

OFFICIAL BUSINESS

COMMANDER
U.S. ARMY AVIATION AND TROOP COMMAND
ATTN: AMSAT-I-MP
4300 GOODFELLOW BOULEVARD
ST. LOUIS, MO 63120-1798

TEAR ALONG PERFORATED LINE

RECOMMENDED CHANGES TO EQUIPMENT TECHNICAL PUBLICATIONS



THEN... JOT DOWN THE DOPE ABOUT IT ON THIS FORM. CAREFULLY TEAR IT OUT. FOLD IT AND DROP IT IN THE MAIL.

SOMETHING WRONG WITH THIS PUBLICATION?

FROM: (PRINT YOUR UNIT'S COMPLETE ADDRESS)

DATE SENT

PUBLICATION NUMBER
TM 9-6115-645-10

PUBLICATION DATE
30 July 1993

PUBLICATION TITLE
GENERATOR SET, SKID MOUNTED

BE EXACT PIN-POINT WHERE IT IS

PAGE NO. PARAGRAPH FIGURE NO. TABLE NO.

IN THIS SPACE TELL WHAT IS WRONG AND WHAT SHOULD BE DONE ABOUT IT:

PRINTED NAME GRADE OR TITLE AND TELEPHONE NUMBER

SIGN HERE

FILL IN YOUR
UNITS ADDRESS



FOLD BACK

DEPARTMENT OF THE ARMY

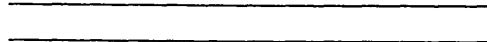

OFFICIAL BUSINESS

COMMANDER
U.S. ARMY AVIATION AND TROOP COMMAND
ATTN: AMSAT-I-MP
4300 GOODFELLOW BOULEVARD
ST. LOUIS, MO 63120-1798

TEAR ALONG PERFORATED LINE

RECOMMENDED CHANGES TO EQUIPMENT TECHNICAL PUBLICATIONS



SOMETHING WRONG WITH THIS PUBLICATION?

THEN... JOT DOWN THE DOPE ABOUT IT ON THIS FORM. CAREFULLY TEAR IT OUT. FOLD IT AND DROP IT IN THE MAIL!

FROM (PRINT YOUR UNIT'S COMPLETE ADDRESS)

DATE SENT

PUBLICATION NUMBER TM 9-6115-645-10	PUBLICATION DATE 30 July 1993	PUBLICATION TITLE GENERATOR SET, SKID MOUNTED
--	----------------------------------	--

BE EXACT PIN-POINT WHERE IT IS				IN THIS SPACE TELL WHAT IS WRONG AND WHAT SHOULD BE DONE ABOUT IT:
PAGE NO	PARA-GRAPH	FIGURE NO	TABLE NO	

PRINTED NAME GRADE OR TITLE AND TELEPHONE NUMBER	SIGN HERE
--	-----------

1 Nov 80

FILL IN YOUR
UNITS ADDRESS



FOLD BACK

DEPARTMENT OF THE ARMY

OFFICIAL BUSINESS

COMMANDER
U.S. ARMY AVIATION AND TROOP COMMAND
ATTN: AMSAT-I-MP
4300 GOODFELLOW BOULEVARD
ST. LOUIS, MO 63120-1798

TEAR ALONG PERFORATED LINE

RECOMMENDED CHANGES TO EQUIPMENT TECHNICAL PUBLICATIONS



THEN... JOT DOWN THE DOPE ABOUT IT ON THIS FORM. CAREFULLY TEAR IT OUT. FOLD IT AND DROP IT IN THE MAIL!

SOMETHING WRONG WITH THIS PUBLICATION?

FROM (PRINT YOUR UNIT'S COMPLETE ADDRESS)

DATE SENT

PUBLICATION NUMBER TM 9-6115-645-10	PUBLICATION DATE 30 July 1993	PUBLICATION TITLE GENERATOR SET, SKID MOUNTED
--	----------------------------------	--

BE EXACT PIN-POINT WHERE IT IS				IN THIS SPACE TELL WHAT IS WRONG AND WHAT SHOULD BE DONE ABOUT IT:
PAGE NO	PARA-GRAPH	FIGURE NO	TABLE NO	

PRINTED NAME GRADE OR TITLE AND TELEPHONE NUMBER	SIGN HERE
--	-----------

FILL IN YOUR
UNITS ADDRESS



FOLD BACK

DEPARTMENT OF THE ARMY

OFFICIAL BUSINESS

COMMANDER
U.S. ARMY AVIATION AND TROOP COMMAND
ATTN: AMSAT-I-MP
4300 GOODFELLOW BOULEVARD
ST. LOUIS, MO 63120-1798

TEAR ALONG PERFORATED LINE

The Metric System and Equivalents

Linear Measure

1 centimeter = 10 millimeters = .39 inch
 1 decimeter = 10 centimeters = 3.94 inches
 1 meter = 10 decimeters = 39.37 inches
 1 dekameter = 10 meters = 32.8 feet
 1 hectometer = 10 dekameters = 328.08 feet
 1 kilometer = 10 hectometers = 3,280.8 feet

Weights

1 centigram = 10 milligrams = .15 grain
 1 decigram = 10 centigrams = 1.54 grains
 1 gram = 10 decigrams = .035 ounce
 1 dekagram = 10 grams = .35 ounce
 1 hectogram = 10 dekagrams = 3.52 ounces
 1 kilogram = 10 hectograms = 2.2 pounds
 1 quintal = 100 kilograms = 220.46 pounds
 1 metric ton = 10 quintals = 1.1 short tons

Liquid Measure

1 centiliter = 10 milliliters = .34 fl. ounce
 1 deciliter = 10 centiliters = 3.38 fl. ounces
 1 liter = 10 deciliters = 33.81 fl. ounces
 1 dekaliter = 10 liters = 2.64 gallons
 1 hectoliter = 10 dekaliters = 26.42 gallons
 1 kiloliter = 10 hectoliters = 264.18 gallons

Square Measure

1 sq. centimeter = 100 sq. millimeters = .155 sq. inch
 1 sq. decimeter = 100 sq. centimeters = 15.5 sq. inches
 1 sq. meter (centare) = 100 sq. decimeters = 10.76 sq. feet
 1 sq. dekameter (are) = 100 sq. meters = 1,076.4 sq. feet
 1 sq. hectometer (hectare) = 100 sq. dekameters = 2.47 acres
 1 sq. kilometer = 100 sq. hectometers = .386 sq. mile -

Cubic Measure

1 cu. centimeter = 1000 cu. millimeters = .06 cu. inch
 1 cu. decimeter = 1000 cu. centimeters = 61.02 cu. inches
 1 cu. meter = 1000 cu. decimeters = 35.31 cu. feet

Approximate Conversion Factors

To change	To	Multiply by	To change	To	Multiply by
inches	centimeters	2.540	ounce-inches	newton-meters	.007062
feet	meters	.305	centimeters	inches	.394
yards	meters	.914	meters	feet	3.280
miles	kilometers	1.609	meters	yards	1.094
square inches	square centimeters	6.451	kilometers	miles	.621
square feet	square meters	.093	square centimeters	square inches	.155
square yards	square meters	.836	square meters	square feet	10.764
square miles	square kilometers	2.590	square meters	square yards	1.196
acres	square hectometers	.405	square kilometers	square miles	.386
cubic feet	cubic meters	.028	square hectometers	acres	2.471
cubic yards	cubic meters	.765	cubic meters	cubic feet	35.315
fluid ounces	milliliters	29.573	cubic meters	cubic yards	1.308
pints	liters	.473	milliliters	fluid ounces	.034
quarts	liters	.946	liters	pints	2.113
gallons	liters	3.785	liters	quarts	1.057
ounces	grams	28.349	liters	gallons	.264
pounds	kilograms	.454	grams	ounces	.035
short tons	metric tons	.907	kilograms	pounds	2.205
pound-feet	newton-meters	1.356	metric tons	short tons	1.102
pound-inches	newton-meters	.11296			

Temperature (Exact)

°F	Fahrenheit temperature	5/9 (after subtracting 32)	Celsius temperature	°C
----	------------------------	----------------------------	---------------------	----

